



Construction

Military

Trucking

Farming

Railroad

D.A. INTERNATIONAL CASTING CO.

Your Link to the International Market
Rail Car Division



In 1996, David Alan Kerrigan founded D.A. International Casting Company. He started with nothing more than a vision of a successful casting business, a dedication to customer service, and a small rented space in central Ohio. With a couple of sand casting samples, and one potential customer, David began his quest to forge his way in the casting industry.

Today, D.A. International Casting Company has grown to serve over 800 customers and stocks over 1,100 different products. David attributes part of this success to the purchase of Racine Steel and Wine Railcar. Since 1903, Wine Railcar has provided top quality castings to the railroad industry.

Over the years, D.A. has expanded their products to include premium investment castings, forgings, stampings and fabrications. This extensive inventory allows the company to now accommodate multiple markets, such as the railroad industry, mass transit, agriculture, heavy trucking, mining and telecommunication.

Visit D.A. International Casting Company's state of the art 100,000 square-foot facility in Mansfield, Ohio, full of OEM and custom stock. See for yourself why we are an industry leader that is excited to meet your company's specific needs.

David Alan Kerrigan
CEO/President





CONTACT US

Phone: 419-522-2278 (CAST)

Fax: 419-524-1688

Monday through Friday 8:00 am – 5:00 pm

www.dacasting.com



David Kerrigan, President/CEO

Email: d.kerrigan@dacasting.com



Mark Carifa, VP of Operations/Sales

Email: m.carifa@dacasting.com



Heather Kerrigan, Public Relations

Email: h.kerrigan@dacasting.com



Jodi Ditmars, Office Manager/Accounting

Email: j.ditmars@dacasting.com



Ryan Rebillot, Quality Control

Email: r.rebillot@dacasting.com



D. A. International Casting Company
23 Industrial Parkway
Mansfield, OH 44903
Phone: 419-522-2278 (Cast)

QUALITY MANUAL

Rev. 04 27 10 by JA

Originator: Management Rep.

Page 1 of 1

QUALITY POLICY

Quality at D.A. International Casting Company is a fundamental business commitment.

Our goal is to become the best in the international marketplace in which we participate.

We are committed to providing our customers with the highest quality products and services, on time, at the best possible value.

It is D.A. International Casting Company's policy for all D.A. personnel to meet and exceed the requirements stated in our Quality Manual;

*Quality Products, Backed By Quality Service
& a Commitment to Excellence!!*

David A Kerrigan
President

The management of D.A. International Casting Company has formulated this policy. The policy is understood, maintained and implemented at all levels of the organization. Its focus is D.A. International Casting Company's organizational goals and the expectations and the needs of our customers. The policy is explained and discussed at general orientation training given to all existing and new employees. The policy is also issued on cards to each employee.

DA International Casting Co.

Flow Chart

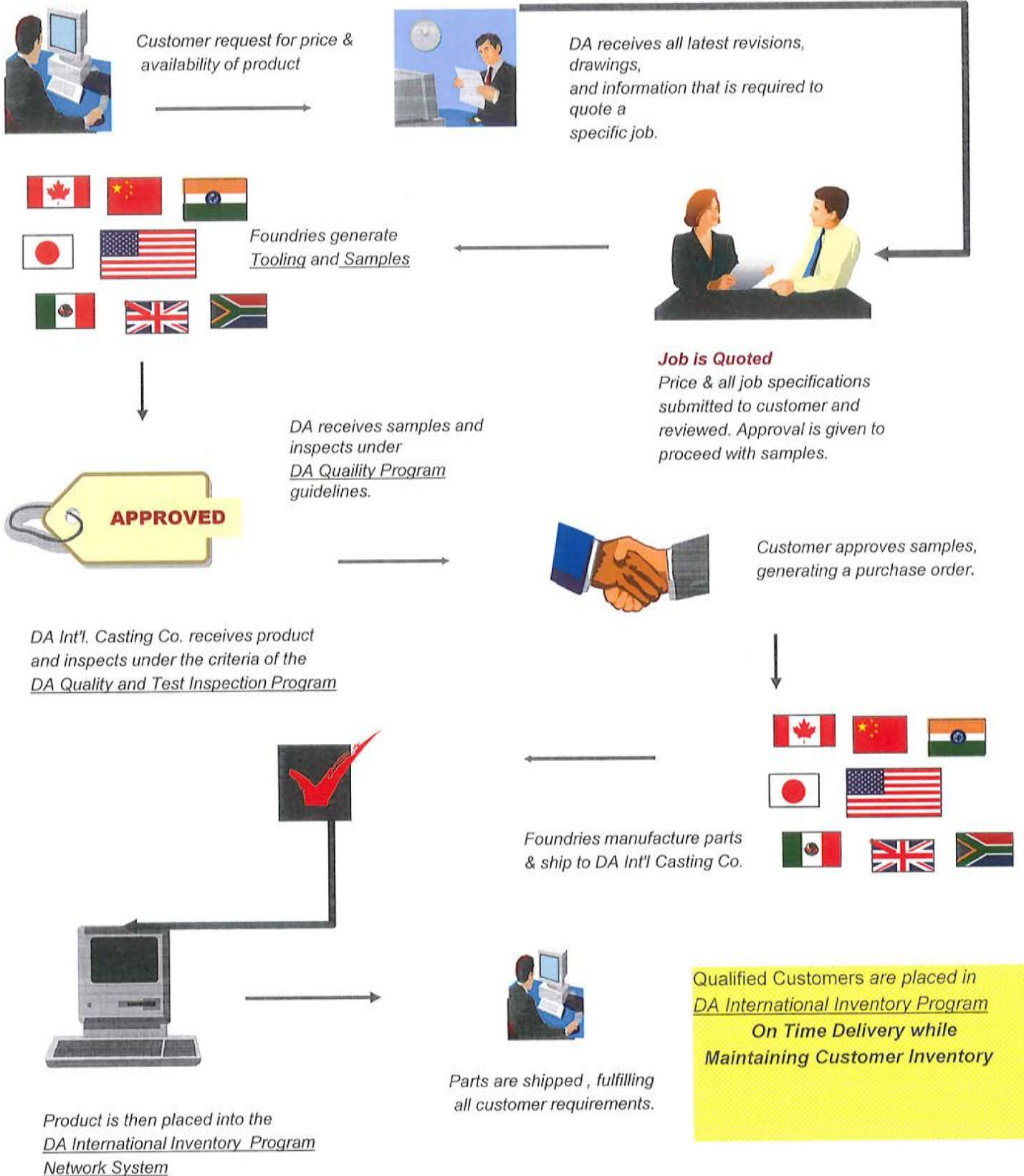

Parts Catalog

D.A. International purchased Wine Railcar Products Co. January 2001

WINE RAILCAR PRODUCTS

Since 1913

DA

WINE PRODUCTS

Member of Railway Supply Association, Inc.

Genuine Wine Products-engineered solutions for your rail car needs

Corner Cap
Four different styles

Foot for Cross Brace, Floor End

Heavy Duty Discharge Gates
Interchangeable parts for all makes and models, pinion, capstan, doors, racks, etc.

Truck Dead Lever Clevis Brackets

Hopper Door Frame/Locks/Hinges

Draft Stops

Single Door Cam Locks

Double Adjustable Locks

Vibrator Brackets
Ten different styles
Weld or bolt on

D.A. International Casting Company

D.A. Stocks over 350 different size, shape, and grades of castings for all makes and models of freight cars. Complete parts catalog available January 2002.

23 Mansfield Industrial Pkwy
Mansfield OH 44903
Phone: 419-522-2278 (CAST)
Website: www.dacasting.com

World-wide importer, insuring the highest quality and best prices available.

Complete Line of Wine Railcar Products

- Replacement castings and fabrications for most makes and models of Gravity Discharge Gates.
- Miscellaneous castings, forgings and fabrications for all freight cars.

Picture shown is for left handed opening which includes the following:

- | | |
|-----------------------------------|----------------------|
| 1 Hopper Frame | 1 Spreader Extension |
| 1 Hopper Door, carbon steel or SS | 1 Locking Pawl |
| 2 Universal Hinges | 1 Fulcrum Bracket |
| 2 Hinge Pins | 1 Latch (Hook) |
| 1 Adjusting Eccentric | 1 Trunnion |
| 1 Spreader Beam | |

Newly Renovated Warehouse,
Orders processed within one business day

GENU-WINE[®] WINE[®] Railcar Products

100 Years of Quality

- Best Quality, Best Price
Don't Settle for Imitations
- Quality Freight Car Parts for
over 100 years
- Over 180 Wine[®] Parts In-Stock
- Solid Cast Reinforced
Hopper Frames
- Parts Catalog Now Available

DA

Member of
RSI
Railway Supply Institute

23 Industrial Parkway, Mansfield, OH 44903
Call: (419) 522-2278 (CAST) • Fax: (419) 524-1688

visit our complete catalog at www.dacasting.com

D.A. International Casting Company
World-wide importer, insuring the highest
quality and best prices available.

WINE RAILCAR PRODUCTS Since 1908
D.A. Int. purchased Wine[®] Railcar Products Co. Jan. 2001

Rapid - Release™

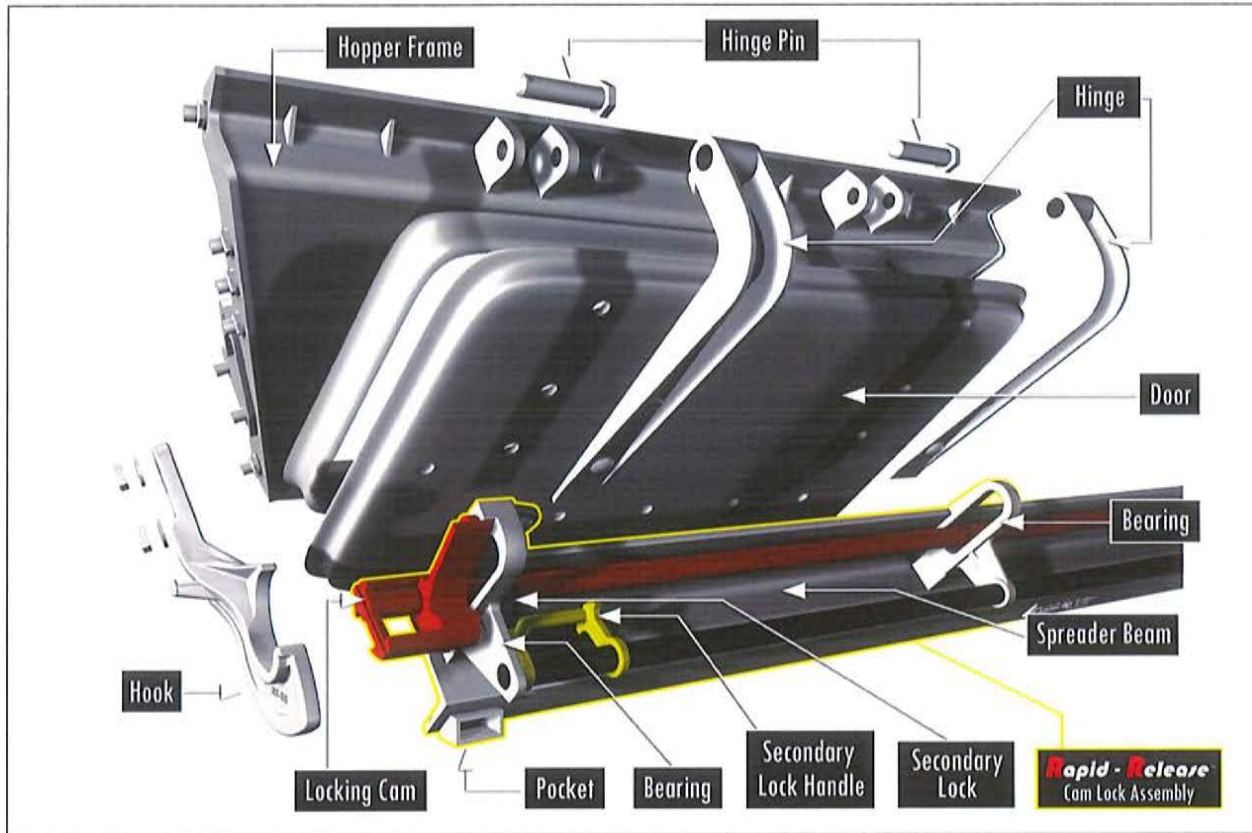

Door Size	Floor Slope	Hopper Frame P/N	Left Hook	Right Hook	RR Cam Lock Assembly P/N
Narrow	30 degree	HF-259/216	DA-00611, RR-611-L	DA-00612, RR-611-R	DA-00640-1
Wide	30 degree	HF-212	DA-00651, RR-651-L	DA-00652, RR-651-R	DA-00642-1
Wide	45 degree	HF-238	DA-00659, RR-659-L	DA-00660, RR-659-R	DA-00642-1

Rapid - Release is D. A. International Casting Company's most advanced WINE manual door lock system and it offers the following advantages:

- ✓ Designed using the same technology as the proven single door cam lock system, but requires fewer parts than that of a pair of single door cam locks.
- ✓ One person can operate a pair of hopper doors from either side of the rail car.
- ✓ Easy to install on new or existing conventional hopper cars.
- ✓ Built WINE tough and features dual outboard hooks to help support the commodity more evenly.
- ✓ This patented design features over-center locking cams which are self locking when the car is loaded.
- ✓ A secondary lock is built in for added safety and as a provision to operate in rotary dump service.

SEE PAGE 25.1 FOR RAPID RELEASE CATALOG PARTS SECTION

**D.A. International Casting Co.
Part Numbers**

DA P/N	Ref. #	Description	Drwg. #	Weight	Page #	1-9	10-24	25-49	50-99	100-199	200+
DA-12200	PC-122	Bar Socket	PC-122	4.5	33	Call for Quantity Price Breaks					
DA-23108	2CH-258	Bearing	2CH-258	1.8	3						
DA-61272	2CH-642-A	Bearing	2CH-642	8.6	3						
DA-63282	2CH-642-B	Bearing	2CH-642	8.6	4						
DA-14504	CL-4-A	Bearing	2CL-4	4.0	3						
DA-14514	CL-4-B	Bearing	2CL-4	4.0	3						
DA-13413	CL-3-A	Bearing	3CL-3	6.5	3						
DA-13423	CL-3-B	Bearing	3CL-3	6.5	3						
DA-43433	PK-433	Bearing Block	2BX-1081-B	0.5	4						
DA-00648	DA-648	Bearing Block	DA-00648	2.8	26						
DA-11008	PC-118	Bearing-Center	PC-118	5.5	33						
DA-12000	PC-120	Bearing-Outer	PC-120	6.0	33						
DA-53619		Bell Crank, AAR 55		9.4	27.1						
DA-53850		Bell Crank, AAR 66		11.8	27.1						
DA-03654	DA-3654-140	Bolster Rim Replacement	DA-3654	13.6	26						
DA-03710	DA-3709-141	Bolster Rim Replacement	DA-3709	13.6	26						
DA-03711	DA-3709-160	Bolster Rim Replacement	DA-3709	13.6	26						
DA-18176	PK-176-A	Bracket	3BX-789	6.5	4						
DA-18276	PK-176-B	Bracket	3BX-789	6.5	4						
DA-30341	PK-341-A	Bracket	3BX-859	7.0	4						
DA-31341	PK-341-B	Bracket	3BX-859	7.0	4						
DA-45482	PK-482-A	Bracket	3BX-1191	7.0	5						
DA-46482	PK-482-B	Bracket	3BX-1191	7.0	5						
DA-31513	MC-410	Bracket, Clevis	3MC-410	8.8	7						
DA-48234	PK-482-A-34	Bracket	3BX-1191	7.0	15						
DA-48334	PK-482-B-34	Bracket	3BX-1191	7.0	15						
DA-04268	T-130	Bracket, Fulcrum	T-130	9.3	35						
DA-43514	MC-514	Bushing		1.2	5						
DA-17012	CL-2-A	Cam Lock (In)	3CL-2	4.3	6						
DA-17023	CL-2-B	Cam Lock (In)	3CL-2	4.3	6						
DA-17111	CL-1-B	Cam Lock (Out)	3CL-1	5.5	5						
DA-17011	CL-1-A	Cam Lock (Out)	3CL-1	5.5	5						
DA-10011	CL-1-A-1	Cam Lock (Out)	4CL-67	5.5	6						
DA-10001	CL-1-B-1	Cam Lock (Out)	4CL-67	5.5	6						
DA-41511	4CL-15-1	Camlock Assembly, (LH)	4CL-15	60.0	6						
DA-41512	4CL-15-2	Camlock Assembly, (LH)	4CL-15	64.0	6						
DA-41611	4CL-16-1	Camlock Assembly, (RH)	4CL-16	60.0	6						
DA-41612	4CL-16-2	Camlock Assembly, (RH)	4CL-16	64.0	6						
DA-01211	2CH-121	Capstan	2CH-121	7.6	7						
DA-42391	DA-4081	Capstan	DA-4081	7.8	26						
DA-25690		Capstan		9.6	27						
DA-43413	DA-403	Capstan	DA-403	13.0	26						
DA-10080		Capstan	MKE10080	16.4	26						
DA-16298		Capstan		14.0	27.2						
DA-08843	E-8843	Capstan		14.1	27.2						
DA-33142	2CH-322	Capstan Lock	2CH-322	1.1	7						
DA-41902	DA-402	Capstan, Long Universal	DA-402	17.6	27						
DA-41890	DA-400	Capstan, Short Universal	DA-400	7.6	27						
DA-41932	DA-402-2	Capstan, Long Heavy Duty	DA-402-2	21.0	27						
DA-91701	D965361-2	Capstan Reinforcement	D-986425	2.8	27						
DA-43431	2CH-685	Conversion Kit 61"	2CH-685	100.0	7 & 27						
DA-41424	DA-404	Conversion Kit 66"	DA-404	100.0	7 & 27						
DA-41517	MC-477	Corner Cap	2MC-477	17.2	10						
DA-70100	3864	Corner Cap		11.5	36.1						
DA-41518	DA-700	Corner Cap	DA-700	11.2	37						
DA-32580	3799	Coupler Carrier Wear Plate		6.6	27.1						
DA-32581	3258	Coupler Carrier Wear Plate		8.9	27.1						
DA-40406	MC-406	Crossridge Foot Brace	3MC-406	7.6	7.1						
DA-35350	MC-350	Crossridge Foot Brace	3MC-350	8.5	7						
DA-40900	MC-409	Crossridge Foot Brace	3MC-409	8.5	7						
DA-42387	4CH-257	Door Gate Comp.	4CH-257	388.0	N/A						
DA-43398	4CH-418-RH	Door Gate Comp.	4CH-418	248.6	8						
DA-43388	4CH-418-LH	Door Gate Comp.	4CH-418	248.6	8						
DA-63401	4CH-641	Door Gate Comp.	4CH-641	516.5	8						
DA-49090	DA-490-L	Door Gate Comp. (LH)	DA-490	210.0	N/A						
DA-49091	DA-490-R	Door Gate Comp. (RH)	DA-490	210.0	N/A						
DA-63671		Door Slide Ass'y.	2-B-38-63671		7.1						
DA-21111	2CH-259-1	Door Slide Ass'y.	2CH-259-1	168.9	8						
DA-31139	2CH-309	Door Slide Ass'y.	2CH-309	98.8	8						
DA-21304	3CH-214	Door Slide Ass'y.	3CH-214	200.9	8						
DA-31397	2CH-397	Door Slide Ass'y.	2CH-397	195.0	8						
DA-31313	3CH-303	Door Slide Ass'y.	3CH-303	187.5	8						
DA-32300	2CH-323	Door Slide Ass'y.	2CH-323	154.2	9						
DA-41254	2CH-404	Door Slide Ass'y.	2CH-404	91.3	9						
DA-41328	DA-41328	Door Slide Ass'y.	DA-41328	194.0	9						
DA-41329	3CH-429	Door Slide Ass'y.	3CH-429	195.6	9						
DA-61294	2CH-654-1	Door Slide Ass'y.	2CH-654-1	92.0	9						

**Call for
Pricing**

D.A. International Casting Co.
Part Numbers

DA P/N	Ref. #	Description	Drwg. #	Weight	Page #	1-9	10-24	25-49	50-99	100-199	200+
DA-05374	Style #6	Door Slide Ass'y.	C-53701	78.0	30	Call for Quantity Price Breaks					
DA-07987	DA-7987	Door Slide Ass'y.	DA-07987	154.0	30						
DA-08410	DA-08410	Door Slide Ass'y.	DA-08410	140.0	30						
DA-10062	MKE-10062	Door Slide Ass'y.	DA-10062	134.0	30						
DA-05765	Style #5	Door Slide Ass'y.	D-52807	84.0	31						
DA-50202	Style #2	Door Slide Ass'y.	D-52807	104.0	31						
DA-50203	Style #3	Door Slide Ass'y.	D-52807	71.6	31						
DA-50204	DA-50204	Door Slide Ass'y.	DA-50204		31						
DA-50287	Style #1	Door Slide Ass'y.	D-52807	126.0	31						
DA-05804	Style #4	Door Slide Ass'y.	D-52807	72.0	31						
DA-07118	DA-7118	Door Slide Ass'y.	DA-07118	164.0	31						
DA-78134		Door Slide Ass'y.	DA-78134	145.0	31.1						
DA-50289		Door Slide Ass'y.	DA-50289	128.0	31.1						
DA-71106		Door Slide Ass'y.	DA-71106	166.0	31.1						
DA-71131		Door Slide Ass'y.	DA-71131		31.1						
DA-71140		Door Slide Ass'y.	DA-71140		31.1						
DA-71150		Door Slide Ass'y.	DA-71150		31.1						
DA-74510		Door Slide Ass'y.	DA-04510		31.1						
DA-74520		Door Slide Ass'y.	DA-04510		31.1						
DA-50209	DA-50209	Door Slide Ass'y.	DA-50209	104.0	31.2						
DA-50210	DA-50210	Door Slide Ass'y.	DA-50210		31.2						
DA-71132		Door Slide Ass'y.	DA-71132		31.2						
DA-71132-SP		Door Slide Ass'y.	DA-71132-SP		31.2						
DA-50037	5050037	Door Stop	500B37	2.1	37						
DA-00850-2		Draft Key Retainer	DA-00850-2	2.5	37						
DA-00850-1		Draft Key Retainer Keeper	DA-00850-1	0.4	37						
DA-32220	CB-220	Draft Lug, Rear	2MC-475	42.5	24						
DA-45461	MC-461	Draft Lug, Front	2MC-461	41.0	24						
DA-18004	B-10804	Draft Lug	B-10804	47.0	28						
DA-90346	B-9346	Draft Lug, Rear	B-9346	40.0	28						
DA-15154	50154-R	Draft Lug, RH	DA-15154	41.0	27.1						
DA-15155	50154-L	Draft Lug, LH	DA-15154	41.0	27.1						
DA-10028	CB-128	Draft Lug, Rear	2MC-471	55.0	24						
DA-81777	578106-0	Draft Lug, Front		27.6	27.2						
DA-60606	PK-6	Eccentric	2BX-1158	1.6	10						
DA-31236	PK-36	Eccentric	2BX-779	1.6	10						
DA-11900	PC-119	Eccentric	PC-119	6.5	33						
DA-50068	093-40049	Eccentric Nut		1.4	38						
DA-17025	CL-25	End Cap	1CL-25	0.4	11						
DA-31808	PK-318-A	Extension	3BX-778	7.2	9						
DA-31818	PK-318-B	Extension	3BX-778	7.2	9						
DA-48908	PK-489-A	Extension	3BX-1204	9.5	10						
DA-48918	PK-489-B	Extension	3BX-1204	9.5	10						
DA-32101	PK-321-A	Extension	3BX-786	7.8	11						
DA-32102	PK-321-B	Extension	3BX-786	7.8	11						
DA-40431	PK-431-A	Extension		7.8	11						
DA-41431	PK-431-B	Extension		7.8	11						
DA-41454	PK-454-A	Extension	3BX-1120	8.7	11						
DA-42454	PK-454-B	Extension	3BX-1120	8.7	12						
DA-42457	PK-457-A	Extension	3BX-1126	10.5	12						
DA-43457	PK-457-B	Extension	3BX-1126	10.5	12						
DA-43487	PK-487-A	Extension	3BX-1201	11.0	12						
DA-44487	PK-487-B	Extension	3BX-1201	11.0	12						
DA-47134	PK-471-A-34	Extension	3BX-1163	13.0	12						
DA-47234	PK-471-B-34	Extension	3BX-1163	13.0	13						
DA-48483	PK-483-A	Extension	PK-483	9.6	13						
DA-48493	PK-483-B	Extension	PK-483	9.6	13						
DA-47487	PK-487-AX	Extension	3BX-1201	11.0	13						
DA-48487	PK-487-BX	Extension	3BX-1201	11.0	13						
DA-42467	MC-467	Eyebolt Bracket	2MC-467	7.4	13						
DA-43511	MC-511	Eyebolt Bracket	2MC-511	8.0	14						
DA-31780	DA-3178	Filler	DA-31780	3.0	14 & 35						
DA-28261	PK-261-A	Filler	3BX-667	2.4	14						
DA-29261	PK-261-B	Filler	3BX-667	2.4	14						
DA-12611	PK-261-A-1	Filler	3BX-667	2.4	14						
DA-22611	PK-261-B-1	Filler	3BX-667	2.4	14						
DA-44839	44839	Friction Shoe	DA-44839	23.0	27.1						
DA-50030	093-40030	Fulcrum for Spring Assist	500-41	3.0	39						
DA-28274		Gate Lock Bar Assembly	A-028274		36.1						
DA-30115	212-30115-LH	Guide Finger for Rave Door	212-30115-LH	1.4	34						
DA-30119	212-30119-RH	Guide Finger for Rave Door	212-30119-RH	1.2	34						
DA-50300	DA-503	Handle, Stainless Steel	DA-503	0.6	29						
DA-81690	DA-800040	Hanger for Rave Door	DA-800040	1.6	34						
DA-35323	MC-323	Hatch Lock	2MC-323		15						
DA-50016	093-40019	Hinge	500B16	7.0	28						
DA-42499	MC-499	Hinge	2MC-499	6.1	15						
DA-23261	HF-261	Hinge	3HF-1240	7.5	15						
DA-14011	UC-6, 11140-11	Hinge	1UC-6	8.1	7.1						

Call for Pricing

D.A. International Casting Co.
Part Numbers

DA P/N	Ref. #	Description	Drwg. #	Weight	Page #	1-9	10-24	25-49	50-99	100-199	200+
DA-25202	HF-202	Hinge	2HF-846	9.6	21	Call for Quantity Price Breaks					
DA-45496	MC-496	Hinge	2MC-496		21						
DA-12130	V-12130	Hinge	11146-F	7.1	28						
DA-50092	093-40389	Hinge	500B92	4.6	39						
DA-25127	HF-127	Hinge (see DA-23261)	2HF-527	9.6	15						
DA-50017		Hinge Butt	500-17W	3.8	28						
DA-14043	UC-43	Hinge Butt	1UC-43	10.4	7.1						
DA-10139	11139	Hinge Butt	11139	8.8	16						
DA-43512	MC-512	Hinge Butt	2MC-512	5.0	16						
DA-40391	093-40391	Hinge Butt	500B34	4.5	39						
DA-30113	212-30113	Hinge Leaf , Three Knuckle	C-800035	1.4	34						
DA-30112	212-30112	Hinge Leaf , Two Knuckle	C-800034	0.9	34						
DA-12545	DA-11746	Hinge Pin	CPSX-57-01-0	1.4	16						
DA-22527	PK-27-X	Hook	3BX-1210	8.0	17						
DA-34234	PK-342-34	Hook	3BX-860	8.5	17						
DA-43481	PK-481	Hook	2BX-1192	8.0	17						
DA-48134	PK-481-34	Hook	2BX-1192	8.0	21						
DA-17209	CL-19-A	Hook (In)	3CL-19	9.0	16						
DA-17219	CL-19-B	Hook (In)	3CL-19	9.0	16						
DA-17028	CL-28	Hook (In)	3CL-28	10.0	17						
DA-17160	CL-60	Hook (In)	3CL-60	9.0	17						
DA-17204	CL-24-A	Hook (In)	3CL-24	8.5	18						
DA-17224	CL-24-B	Hook (In)	3CL-24	8.5	18						
DA-17309	CL-39-A	Hook (In)	3CL-39	8.1	18						
DA-17339	CL-39-B	Hook (In)	3CL-39	8.1	18						
DA-17503	CL-13-A	Hook (In)	3CL-13	9.0	19						
DA-17513	CL-13-B	Hook (In)	3CL-13	9.0	19						
DA-17156	CL-66-A	Hook (Out)	3CL-66	8.0	18						
DA-17166	CL-66-B	Hook (Out)	3CL-66	8.0	18						
DA-17349	CL-59-A	Hook (Out)	3CL-59	7.9	19						
DA-17359	CL-59-B	Hook (Out)	3CL-59	7.9	19						
DA-17605	CL-65-A	Hook (Out)	3CL-65	7.5	19						
DA-17665	CL-65-B	Hook (Out)	3CL-65	7.5	19						
DA-17512	CL-12-A	Hook (Out)	3CL-12	8.9	20						
DA-17612	CL-12-B	Hook (Out)	3CL-12	8.9	20						
DA-28020	CL-20-A	Hook (Out)	3CL-20	9.5	20						
DA-28120	CL-20-B	Hook (Out)	3CL-20	9.5	20						
DA-23527	CL-27-A	Hook (Out)	3CL-27	8.0	20						
DA-23627	CL-27-B	Hook (Out)	3CL-27	8.0	20						
DA-17308	CL-38-A	Hook (Out)	3CL-38	7.1	21						
DA-17338	CL-38-B	Hook (Out)	3CL-38	7.1	21						
DA-25527	PK-27	Hook (substitute PK-27-X)	3BX-15	6.0	17						
DA-17060	D1706039	Hopper Door for RD car, Alum.	DA-17060	53.0	29						
DA-17002	D-170-7002	Hopper Door LH for RD car		56.0	31.2						
DA-17003	D-170-7003	Hopper Door RH for RD car		56.0	31.2						
DA-47008	D-004-7008	Hopper Door for RD Car, Inner		573.0	40						
DA-47009	D-004-7009	Hopper Door for RD Car, Outer		606.0	40						
DA-176004	D-170-6004	Hopper Door Large	D-170-6004	97.0	30						
DA-176003	D-170-6003	Hopper Door Small	D-170-6003	114.0	30						
DA-76031		Hopper Door, Trapezoidal, LH		127.5	29						
DA-76035		Hopper Door, Trapezoidal, RH		127.5	29						
DA-25212	HF-212-A	Hopper Frame	4HF-902	175.0	1						
DA-25213	HF-212-B	Hopper Frame	4HF-902	175.0	1						
DA-26238	HF-238-A	Hopper Frame	4HF-1053	170.0	1						
DA-27238	HF-238-B	Hopper Frame	4HF-1053	170.0	1						
DA-25210	HF-210-A	Hopper Frame	4HF-1165	182.0	2						
DA-25211	HF-210-B	Hopper Frame	4HF-1165	182.0	2						
DA-25259	HF-259-A	Hopper Frame	4HF-1219	163.0	2						
DA-25260	HF-259-B	Hopper Frame	4HF-1219	163.0	2						
DA-20209	2CH-209	Latch	2CH-209	0.5	21						
DA-12100	PC-121	Latch	PC-121	11.5	33						
DA-15127	2CH-127-A	Latch Bracket	2CH-127	2.0	5						
DA-15128	2CH-127-B	Latch Bracket	2CH-127	2.0	5						
DA-11007	PC-117	Latch Lug	PC-117	3.5	33						
DA-20210	2CH-210	Latch Retainer	2CH-210	0.5	22						
DA-50044	093-40035	Lever End, Door Operating	093-40035	20.0	40						
DA-52090	DA-500-LH	Lock Weld/Assy. Seal Brkt.	DA-500-LH	3.2	35						
DA-52101	DA-501-RH	Lock Weld/Assy. Seal Brkt.	DA-501-RH	3.2	35						
DA-50772	06772-LH	Lock Weld/Assy. Seal Brkt.	MKE-6772	3.2	35						
DA-50773	06773-RH	Lock Weld/Assy. Seal Brkt.	MKE-6773	3.2	35						
DA-50774	7043	Lock Weld/Assy. Seal Brkt.	DA-50772	3.2	35						
DA-50775	7044	Lock Weld/Assy. Seal Brkt.	DA-50772	3.2	35						
DA-12003	PC-123	Locking Lever	PC-123	1.5	34						
DA-50070	093-40051	Lug for Spring Assist		2.8	39						
DA-68845	204910055.0	Outlet Gate Lock Kit	2D38-66845		16						
DA-17417	CL-7	Pawl	2CL-7	3.0	22						
DA-28112	PK-2-A	Pawl	3BX-728	2.4	22						
DA-29112	PK-2-B	Pawl	3BX-728	2.4	22						
DA-32343	PK-343-A	Pawl	3BX-861	3.0	22						
DA-34343	PK-343-B	Pawl	3BX-861	3.0	22						
DA-43480	PK-480-A	Pawl	2BX-1189	2.5	23						
DA-44480	PK-480-B	Pawl	2BX-1189	2.5	23						

Call for Pricing

D.A. International Casting Co.
Part Numbers

DA P/N	Ref. #	Description	Drwg. #	Weight	Page #	1-9	10-24	25-49	50-99	100-199	200+
DA-33178	2CH-328	Pinion Gear	2CH-328	5.0	23	Call for Quantity Price Breaks					
DA-50090		Pin, for Spring Guide	DA-50090	2.2	39						
DA-21129	2CH-29	Pinion Gear	2CH-29	2.8	23						
DA-69400		Pinion Gear	VPA-694	3.0	32						
DA-70209	DA-29-A	Pinion Gear	DA-70209	2.7	32						
DA-70210	DA-29-B	Pinion Gear	DA-29-B	2.7	32						
DA-33179	2CH-327	Pinion Gear	2CH-327	9.6	23						
DA-52082	DA-502	Pinion Gear	DA-502	4.2	32						
DA-70212		Pinion Gear	DA-70212	1.1	32.1						
DA-10129		Pinion Gear	MKE-10129	2.1	32.1						
DA-41051	1CH-409-3	Pinion Shaft, 30 1/2"	1CH-409-3	20.7	N/A						
DA-21934	1CH-409-1	Pinion Shaft, 30 3/4"	1CH-409-1		N/A						
DA-42010	1CH-409-11	Pinion Shaft, 30"	1CH-409-11	22.0	N/A						
DA-01733		Pinion Shaft, 33"	DA-07177		32						
DA-01723		Pinion Shaft, 36 3/8"	DA-07177	18.0	32						
DA-31001	1CH-340-1	Pinion Shaft, 38 3/8"	1CH-340-1	26.2	23 & 35						
DA-07248		Pinion Shaft, 48"	DA-07177	21.6	32						
DA-34005	1CH-340-5	Pinion Shaft, 53"	1CH-340-5		23 & 35						
DA-31033	1CH-340-3	Pinion Shaft, 61"	1CH-340-3	41.6	23 & 35						
DA-07177		Pinion Shaft, 65"	DA-07177	29.1	32						
DA-33026	1CH-340-16	Pinion Shaft, 66"	1CH-340-16	44.9	23 & 35						
DA-30304	DA-502-SS	Pinion-Stainless Steel	1-4042	4.2	32						
DA-21130	DA-29-304-SS	Pinion-Stainless Steel	DA-21130	2.8	32						
DA-42498	MC-498	Pipe Bracket		11.1	10						
DA-92266	MB-999-5186	Plunger Nose	MB-999-5186	0.8	29						
DA-13096	2CH-156	Rack	2CH-156	5.1	24						
DA-33181	2CH-331	Rack	2CH-331	6.5	24						
DA-00185	DA-10085-2	Rack	DA-00185	14.5	35.1						
DA-10111		Rack	DA-10111	7.0	35.1						
DA-41423	DA-423	Rack	DA-423	10.5	36						
DA-42328	DA-7028	Rack	DA-7028	6.0	36						
DA-42339	DA-4029	Rack	DA-4029	5.4	36						
DA-42340	DA-4030	Rack	DA-4030	6.4	36						
DA-42372	DA-422	Rack	DA-422	9.4	36						
DA-42382		Rack		19.8	36						
DA-42444		Rack		8.5	36.1						
DA-50094		Rack		21.0	36.1						
DA-70213		Rack	DA-70213	3.9	36.1						
DA-00640	RR-640	Rapid Release Cam Lock Ass'y	DA-00640		25.1						
DA-00640-1	RR-640-1	Rapid Release Cam Lock Ass'y	DA-00640-1	238.0	25.1						
DA-00642	RR-642	Rapid Release Cam Lock Ass'y	DA-00642		25.1						
DA-00642-1	RR-642-1	Rapid Release Cam Lock Ass'y	DA-00642-1		25.1						
DA-00611	RR-611-L	Rapid Release Hook (LH)	DA-00611		25.2						
DA-00612	RR-611-R	Rapid Release Hook (RH)	DA-00611		25.2						
DA-00651	RR-651-L	Rapid Release Hook (LH)	DA-00651		25.2						
DA-00652	RR-651-R	Rapid Release Hook (RH)	DA-00651		25.2						
DA-00659	RR-659-L	Rapid Release Hook (LH)	DA-00659		25.2						
DA-00660	RR-659-R	Rapid Release Hook (RH)	DA-00659		25.2						
DA-32272	M-336-5072	Release Handle	M-336-5072	3.1	29						
DA-52801	E-51281	Roping Casting	E-51281	70.0	37						
DA-52802	E-51282	Roping Casting	E-51282	70.0	37						
DA-43279	DA-43279	Seal Cam Assembly	DA-43279	1.5	35						
DA-10992	DA-10992	Spreader Beam	DA-10992		7.1						
DA-10993	DA-10993	Spreader Beam	DA-10993		7.1						
DA-10994	DA-10994	Spreader Beam	DA-10994		7.1						
DA-50069	093-40050	Spring Assembly Bracket		6.2	38						
DA-14123	131-40123	Spring for Spring Assist (Green)		15.7	40						
DA-50038	131-40121	Spring for Spring Assist (White)		13	40						
DA-50039	093-40028	Spring Guide		17.5	38						
DA-50034	50034	Spring Guide Adjustment Plate	DA-50034		39						
DA-09048	50067	Spring Guide and Stop		25.3	38						
DA-50040	093-40029	Spring Guide Bracket		10	38						
DA-50066	093-40047	Spring Guide Bracket Cap		16.9	38						
DA-16966	E-16096-B	Striker & Front Draft Lug	E16096B	106.0	28						
DA-30001	DA-30001	Striker & Front Draft Lug	DA-30001	178.0	27.1						
DA-14100	D-10410-C	Striker & Front Draft Lug	CSX134-7-4867	182.0	27.1						
DA-33505	3505A	Truck Damp	2MC-371	8.0	24						
DA-33605	PK-35	Trunnion Washer	2BX-780	1.6	25						
DA-37345	PK-345	Trunnion Washer	2BX-864-B	2.0	25						
DA-43455	PK-455	Trunnion Washer	2BX-1121	1.7	25						
DA-11224	11224	Vibrator Bracket	11224	24.5	25						
DA-10230	11230	Vibrator Brkt (See DA-11224)	11223	30.0	25						
DA-01710	M-167-5000	Vibrator Bracket, Bolt on	DA-045-2000	36.0	37						
DA-01711	M-167-6000	Vibrator Bracket, Weld on	DA-01711	41.2	37						
DA-11222	11222	Vibrator Bracket	11222	24.5	25						
DA-23193		Wedge Lock Assembly	DA-23193	16.0	36.1						
					27-Jan-21						

Call for Pricing

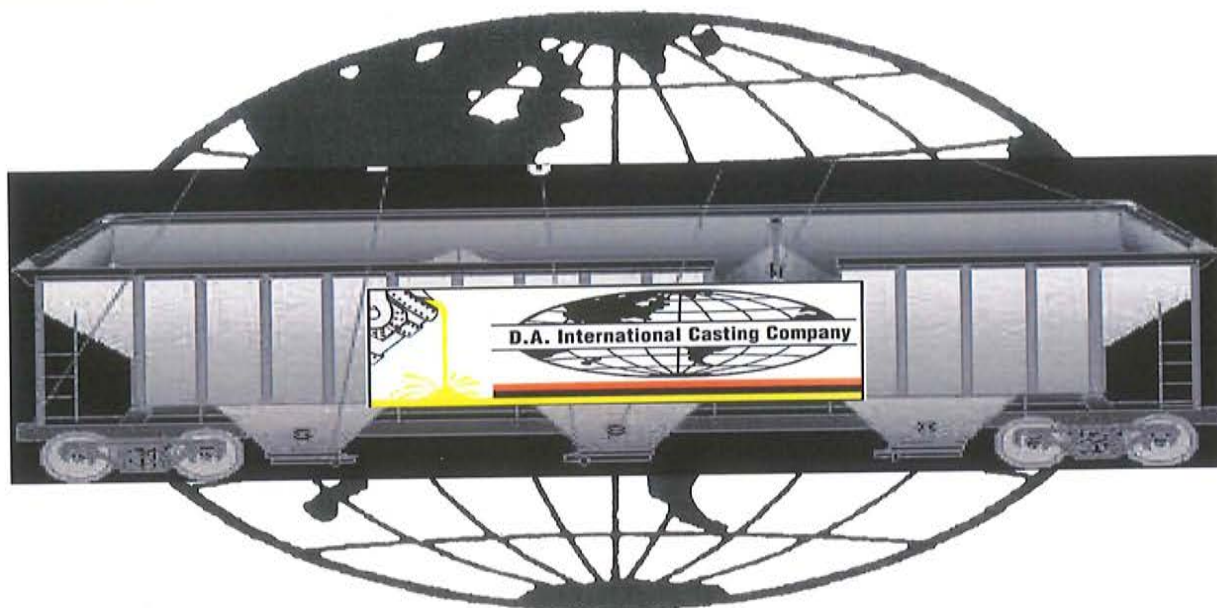

GENU-WINE

**Wine Railcar Products
Designed To Last !!!**

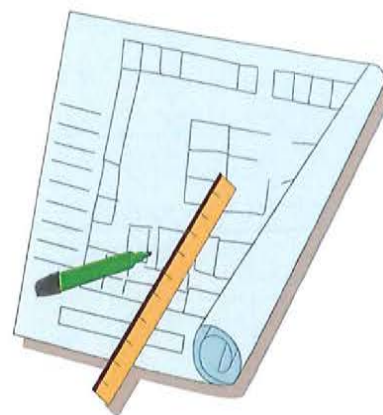

**DON' T SETTLE FOR
IMITATION PARTS !**

**BUY GENUINE
WINE STRENGTH CASTINGS !**

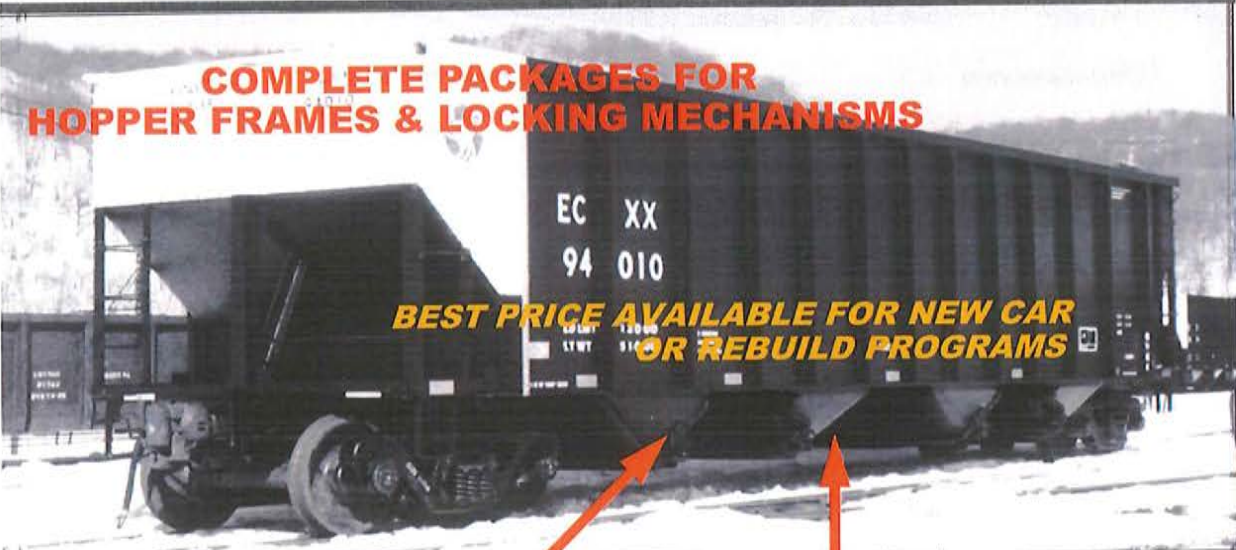

SINGLE DOOR CAM LOCK

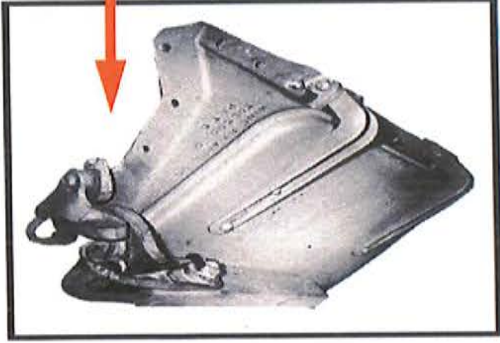

DOUBLE ADJUSTABLE LOCK

COMPLETE (PER OPENING) PACKAGE INCLUDES:

- 1 HOPPER FRAME
- 1 DOOR PAN
- 2 UNIVERSAL HINGES
- 2 FORGE HINGE PINS
- 1 CAM LOCK HOOK CASTING
- 1 COMPLETE CAM LOCK ASSEMBLY

- 1 HOPPER FRAME
- 1 DOOR PAN
- 2 UNIVERSAL HINGES
- 2 FORGE HINGE PINS
- 1 HOOK CASTING
- 1 BRACKET CASTING
- 1 PAWL CASTING
- 1 EXTENSION CASTING
- 1 ECCENTRIC CASTING
- 1 TRUNNION WASHER CASTING

CALL FOR CURRENT PACKAGE PRICING !

WINE RAILCAR PRODUCTS



D.A. International Casting Company

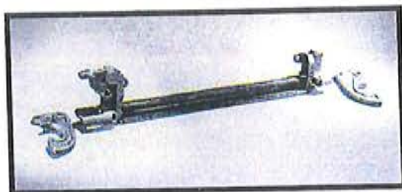
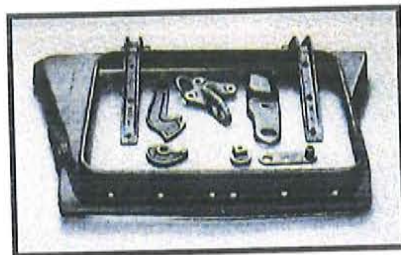
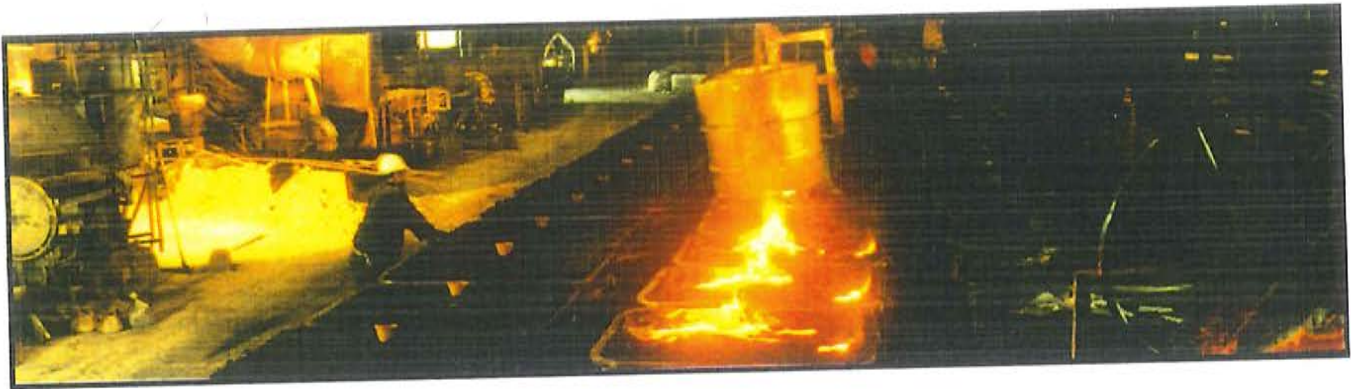

*"Supplying Quality Hopper Door
Frames, Locks, Hinges And Other
Engineered Products For Over 75 Years"*

WINE PRODUCTS - ENGINEERED SC

In addition to the items presented here, many other products have gained wide acceptance in the industry due to their sound engineering, long life and reasonable cost.



Examples are:

- Gears, Racks and Capstans
- Lock parts for Autorack Cars
- Clevis Brackets for Brake Systems
- Rapid Discharge Coal Car Link Stems, and other associated parts

Wine Rail Products, D.A. International Casting Co. is poised to supply castings of greater size and proportion (up to 2,000 lbs.) due to the recent expansion of the foundry and heat treatment capabilities.



Wine Rail Products D.A. International Casting Co. track record in providing innovative, cost effective, quality products and providing experienced field support has been second to none in the industry.

Give us the opportunity to design a product to meet your future needs.



CORNER CAP

Our cast corner cap has proven to be a most effective means of reinforcing corners. This is due to our ability to cast heavier metal wall thicknesses in strategic, critical areas. Available for bolted and welded applications.

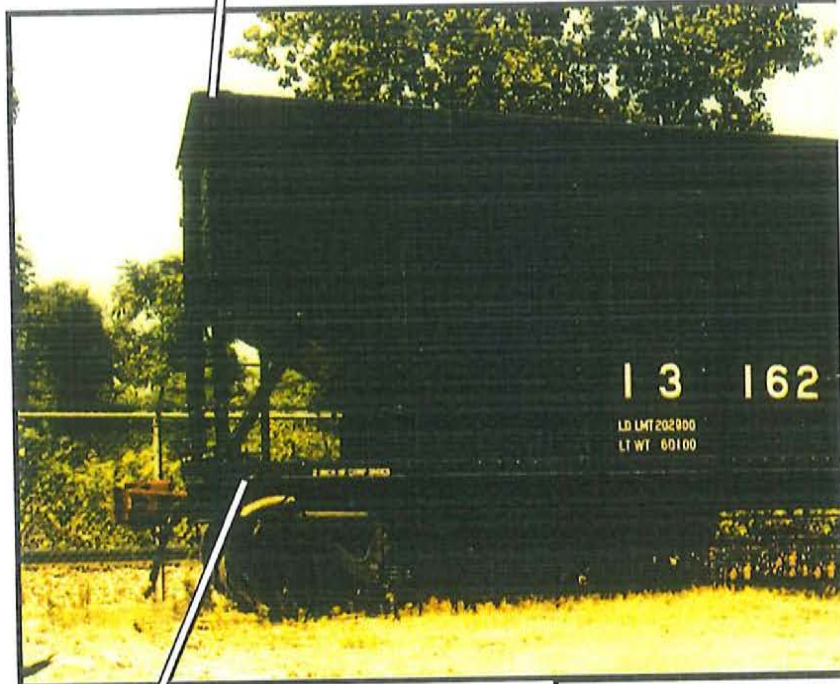

Hopper Door Fra

Either with
Single Door Cam Locks

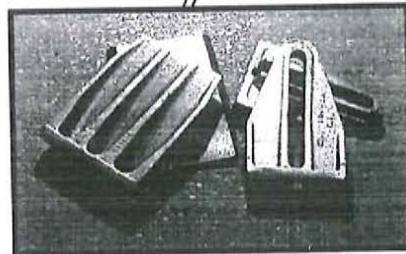

DRAFT STOPS

Many varieties of draft stops are available for either welded or bolted application to various car types including intermodal and hopper cars.

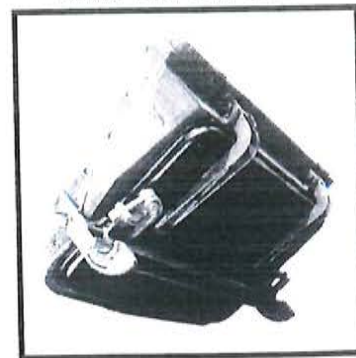

WINE HOPPER DOOR LOCKS D.A. International Casting Co. furnishes two types of door Door Lock and Cam-Lock are used for double chute discharge and single chute discharge re: industry around 1918 and the Single Door Lock in 1960. With Double Door Locks, all parts the system. In addition, the customer must also furnish a spreader bar to connect both side advantages of this system is low cost (less parts) and safety (both doors open simultaneous is designed to be adjusted manually to compensate for wear maintaining a tight fit between c and shipped to the customer ready for application. The Cam-Lock system is easier to install wear adjustment necessary) than the Double Door Lock. Both lock systems have proven to the life of the car.

APPLICATIONS FOR YOUR RAILCAR NEEDS

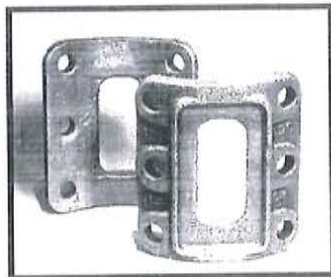

FOOT FOR CROSS RIDGE BRACE, FLOOR END

Cross Ridge bracing with a foot on each end reinforces the sides of open top hoppers. Several designs of our floor end foot casting are available to choose from depending on bracing requirements and slope angle of floor sheets. A cast foot provides optimum strength and dependability.

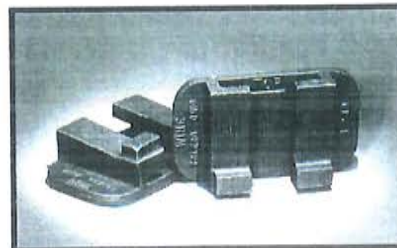

VIBRATOR BRACKETS

Various styles of heat treated cast steel brackets are used on covered hopper cars. Brackets are available for bolted and welded applications.

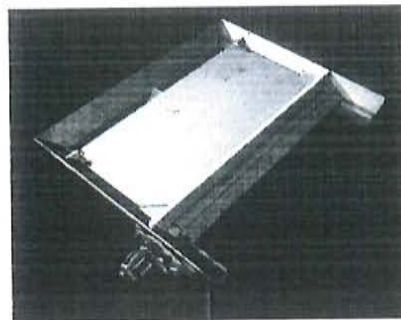
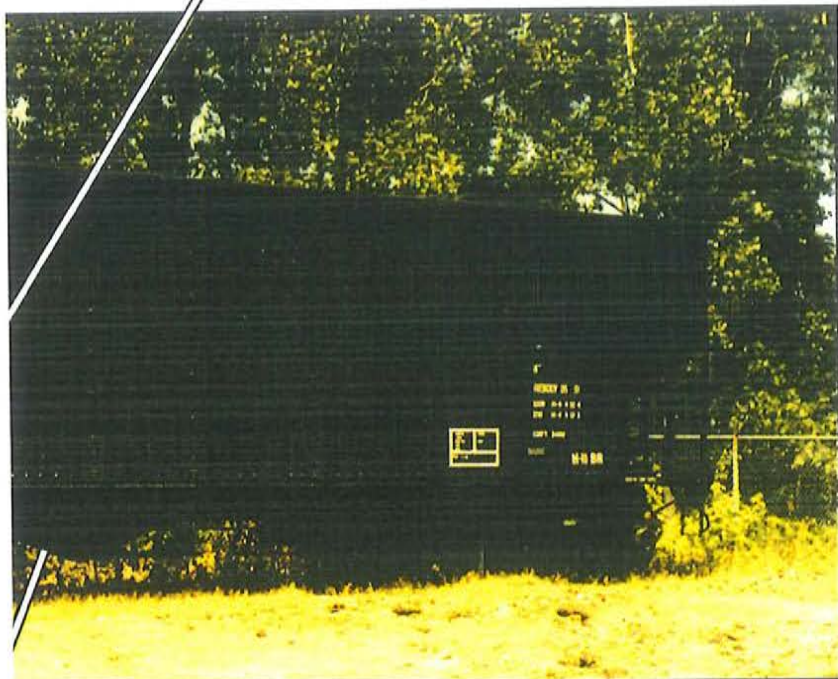

DISCHARGE GATES - HEAVY DUTY

The first Wine Discharge Gate for covered hoppers was introduced in 1932. In 1959, a power geared gate was introduced. Today, AAR certified direct drive gates with fabricated frames are provided for the controlled discharge by gravity of dry bulk commodities. Current gate frames utilize $3/8"$ - $7/16"$ thick steel plate, making them more suited for heavier bulk commodities such as cement. Lighter, less costly gates can be supplied upon request for other, less demanding commodity loading environments. Direct Drive gates are furnished in the following clear opening sizes: $13" \times 24"$, $13" \times 42"$, $24" \times 30"$, $25" \times 47 1/4"$.

LOCKS / HINGES

Or With
Double Adjustable Locks



TRUCK DEAD LEVER CLEVIS BRACKETS

We supply an end sill mounted, cast brake for car mounted brake systems.

go with frames and hinges. The Double Adjustable
ly. The Double Door Lock was introduced to the
ped loose allowing the customer to assemble
lock system across the two doors. The main
parts are rugged, yet light-weight and the system
l frame. The Cam-Lock system is pre-assembled
rivets), operate (cam-action), and maintain (no
ble, reliable and dependable and will generally last

HOPPER DOOR HINGES Cast steel hopper door hinges have been the preferred product for years providing greater strength per pound and a matched fit to the D.A. International Casting Co. Frame ensuring optimum door alignment. A range of Hinges are available including the more popular standard, bushed and deep bellied varieties. Hinges can be furnished for riveted or welded application. Contact D.A. International Casting Co. for assistance in determining the Hinge you need.

HOPPER DOOR FRAMES (Page Over)

HOPPER DOOR FRAMES

The benefits of Cast Steel Hopper Door Frames versus Fabrication are proven. A cast frame provides a means of properly locating the Wine door locks and hinges. It provides an exclusive, uniform taper fit (see illustration below) between frame and door. A cast frame strengthens the hopper chute eliminating the potential for frame breakage found with fabrications. Between 2 and 3 million frames have been applied since 1928.

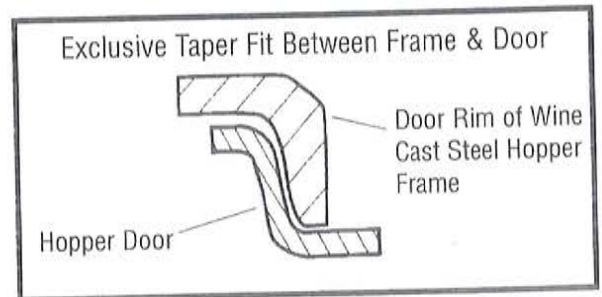
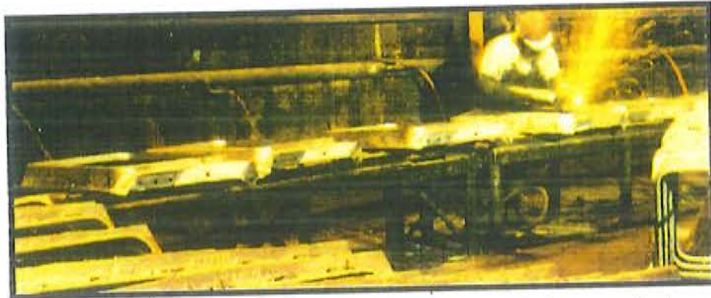

Hopper frames can be provided for any saw-tooth hopper chute arrangement. Many frame designs are available to suit all slope sheets angles. D.A. International Casting Co. Engineering require the following information to determine the frame best suited to your application:

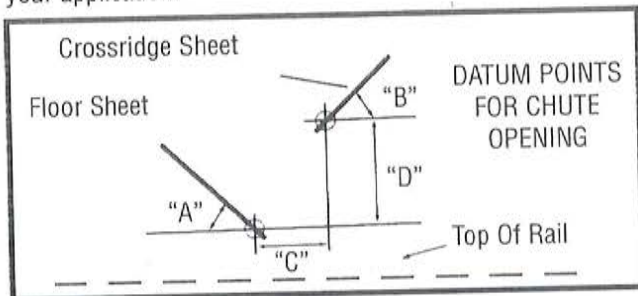

- Number of hopper chutes
- Size and shape of discharge opening desired
- Slope of Floor Sheet and Crossridge Sheet
- Centersill design
- Door Locks to be used. Single Chute-Camlock, Double Chute - Double Adjustable Locks
- Location of Datum Points locating the chute opening relative to top of rail
- Desired means for attaching frame to chute (ie, riveted, welded)

The Frame Application Table below and the Chute Opening Datum Point schematic above will be most helpful in identifying which frame best suits your application. If none exists on the table, we would gladly engineer a frame for you.

HOPPER FRAME APPLICATION TABLE

HOPPER FRAME PATT. NO.	SIZE OF OPENING	*SHAPE	ANGLE OF FLOOR/	ANGLE OF CROSSRIDGE	TYPE OF CTR.SILL	DATUM	POINTS	RIVETED OR WELDED
			"A"	"B"		"C"	"D"	
HF 63 A, B 3	25-3/4 X 37-3/4	T	35°	35°	Zee	17-7/8	23-5/8	R
A, B 4	25-3/4 x 37-3/4	T	52° 30'	52° 30'	Zee	17-7/8	23-5/8	R
A, B 6	25-3/4 x 37-3/4	T	40°	40°	Zee	15-3/4	25	R
HF 99 A, B	25-3/4 x 35-3/4	R	30°	30°	Zee	15-3/4	25	R/W
HF 137 A, B	25-1/2 x 35-1/2	R	30°	30°	Zee	14-21/32	25-1/8	R
HF 178 A, B	25-3/4 x 35-3/4	R	30°	32° 33'	Zee	15-3/4	25	R
HF 204 A, B	25-5/8 x 35-5/8	R	30°	30°	Zee	15-3/4	25	R
HF 210 A, B	25-27/32 x 35-3/4	R	45°	45°	Zee	18-31/32	22-1/16	R/W
HF 212 A, B	25-3/4 x 42	R	30°	30°	Weirton	21-1/2	22-13/16	R/W
HF 216 A, B	25-3/4 x 35-3/4	R	30°	30°	Zee	21-1/2	22-13/16	R/W
HF 227 A, B	25-15/32 x 35-1/2	R	30°	30°	Zee	19	21-3/8	W
HF 238 A, B	25-3/4 x 42	R	45°	45°	Weirton	19-7/8	22-1/4	R
HF 238 A, B 4	25-3/4 x 42	R	45°	45°	Tube	19-7/8	22-1/4	W
HF 239 A, B	25-3/4 x 35-3/4	R	45°	45°	Zee	19-7/8	22-1/4	R/W
THF 249 A, B	25-7/8 x 38-1/8	T	30°	30°	Zee	15-3/4	25	W
THF 250 A, B	25-7/8 x 41-1/2	T	30°	30°	Weirton	15-3/4	25	W

Double adjustable locks are suitable for any frame. Cam locks are appropriate for frames HF99, HF178, HF212, HF216, HF227, and HF238.

*[R - Denotes Rectangular Opening. T - Denotes Trapezoidal Opening.]



D.A. International Casting Co.

23 Industrial Parkway, Mansfield, OH 44903
 Phone: 419-522-(CAST) 2278 • Fax: 419-524-1688
 Website: www.dacasting.com



We also supply doors!

**Carbon Steel
or
SS Steel Available**

See index for complete part listings!!!!
(see pgs. 29 & 30)

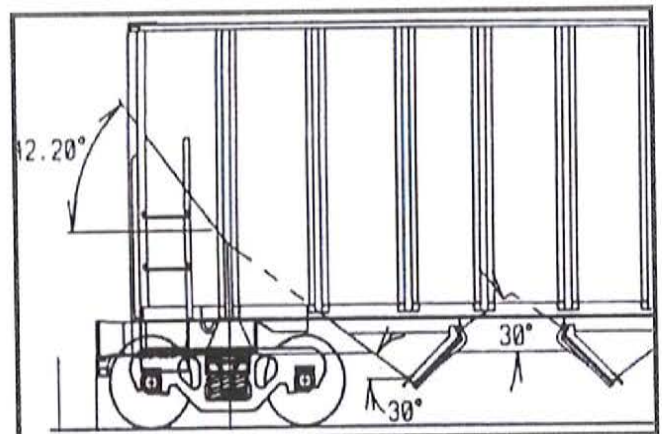

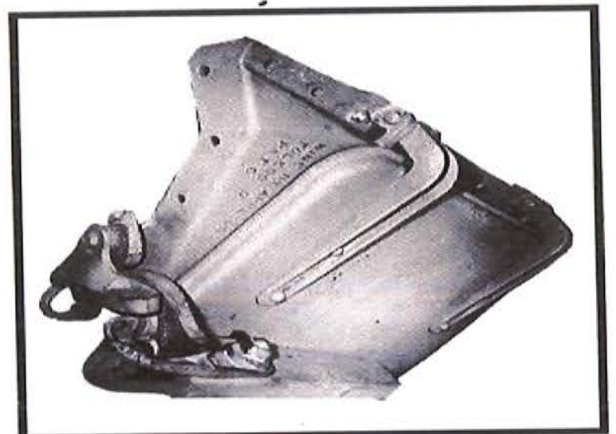



DA Part # : DA-13413
Ref # : CL-3-A
Description: BEARING



DA Part # : DA-13423
Ref # : CL-3-B
Description: BEARING



DA Part # : DA-14504
Ref # : CL-4-A
Description: BEARING

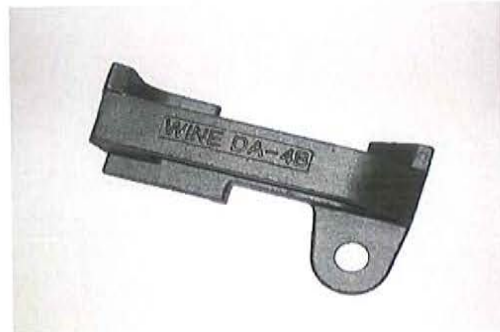

DA Part # : DA-14514
Ref # : CL-4-B
Description: BEARING



DA Part # : DA-23108
Ref # : 2CH-258
Description: BEARING



DA Part # : DA-61272
Ref # : 2CH-642-A
Description: BEARING



DA Part # : DA- 63282
 Ref # : 2CH-642-B
 Description: BEARING



DA Part # : DA- 43433
 Ref # : PK-433
 Description: BEARING BLOCK



DA Part # : DA- 18176
 Ref # : PK-176-A
 Description: BRACKET



DA Part # : DA- 18276
 Ref # : PK-176-B
 Description: BRACKET



DA Part # : DA- 30341
 Ref # : PK-341-A
 Description: BRACKET



DA Part # : DA-31341
 Ref # : PK-341-B
 Description: BRACKET



DA Part # : DA- 45482
Ref # : PK-482-A
Description: BRACKET



DA Part # : DA- 46482
Ref # : PK-482-B
Description: BRACKET



DA Part # : DA-15127/ DA-15128
Ref # : CH-127-A / -B
Description: LATCH BRACKET



DA Part # : DA- 43514
Ref # : MC-514
Description: BUSHING



DA Part # : DA- 17111
Ref # : CL-1-B
Description: CAM LOCK



DA Part # : DA- 17011
Ref # : CL-1-A
Description: CAM LOCK



DA Part # : DA- 10011
 Ref # : CL-1-A-1
 Description: CAM LOCK



DA Part # : DA- 10001
 Ref # : CL-1-B-1
 Description: CAM LOCK



DA Part # : DA- 17012
 Ref # : CL-2-A
 Description: CAM LOCK



DA Part # : DA- 17023
 Ref # : CL-2-B
 Description: CAM LOCK

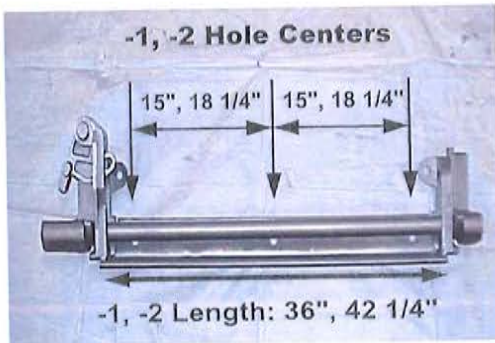

DA Part # : DA- 41511, DA- 41512
 Ref # : 4CL-15-1, 4CL-15-2
 Description: LH CAM LOCK ASS'Y

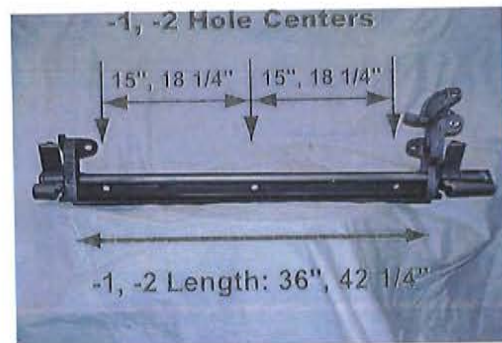

DA Part # : DA- 41611, DA- 41612
 Ref # : 4CL-16-1, 4CL-16-2
 Description: RH CAM LOCK ASS'Y

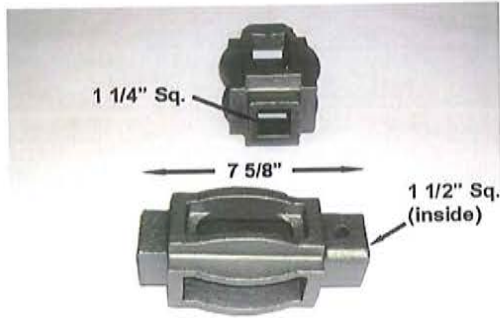

DA Part # DA-01211
 Ref # : 2CH-121
 Description: CAPSTAN

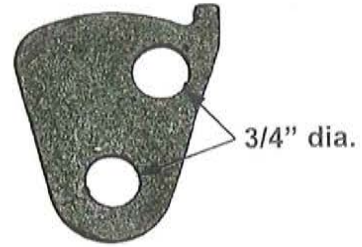

DA Part # : DA-33142
 Ref # : 2CH-322
 Description: CAPSTAN LOCK



DA Part # : DA- 40900
 Ref # : MC-409
 Description: CROSSRIDGE FOOT BRACE
 33° - 9' BRACE 45° SHEET

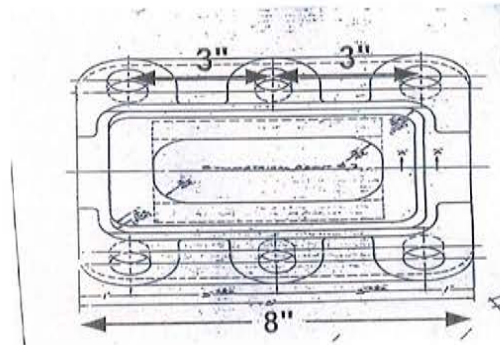

DA Part # : DA- 35350
 Ref # : MC-350
 Description: CROSSRIDGE FOOT BRACE
 33° - 9' BRACE 30° SHEET



DA Part # : DA- 31513
 Ref # : MC-410
 Description: BRACKET, CLEVIS



DA Part # : DA- 43431, DA-41424
 Ref # : 2CH-685, DA-404
 Description: Replacement for Power
 Unit
 Shaft Lengths : 61", 66"



DA Part # DA-40406
Ref # : MC-406
Description: CROSSRIDGE FOOT BRACE



DA Part # : DA-10992, DA-10993, DA-10994
Ref # :
Description: SPREADER BEAM, 3 SIZES



DA Part # : DA- 14011
Ref # : UC-6, 11140-11
Description: HINGE



DA Part # : DA- 14043
Ref # : UC-43
Description: HINGE BUTT

*Future
New Product*

DA Part # :
Ref # :
Description:

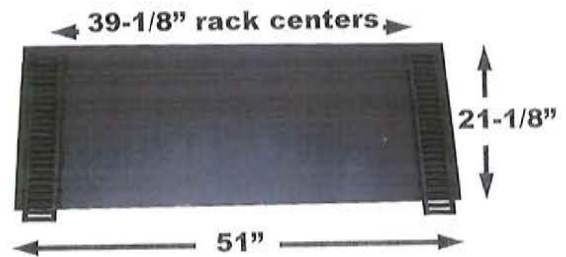

DA Part # : DA-63671
Ref # : WINE
Description: DOOR SLIDE ASS'Y



DA Part # : DA- 43388, DA-43398
 Ref # : 4CH-418 (LH, RH)
 Description: DOOR GATE COMPLETE



DA Part # : DA- 63401
 Ref # : 4CH-641
 Description: DOOR GATE COMPLETE
 Available in several sizes



DA Part # : DA- 21111
 Ref # : 2CH-259-1
 Description: DOOR SLIDE ASSY



DA Part # : DA- 21304, DA- 31397
 Ref # : 3CH-214, 2CH-397
 Description: DOOR SLIDE ASSY



DA Part # : DA- 31139
 Ref # : 2CH-309
 Description: DOOR SLIDE ASSY

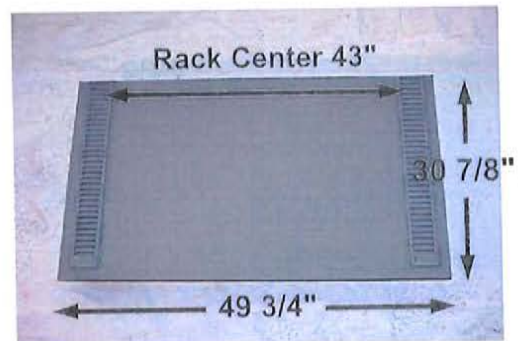

DA Part # : DA- 31313
 Ref # : 3CH-303
 Description: DOOR SLIDE ASSY



DA Part # : DA- 32300
 Ref # : 2CH-323
 Description: DOOR SLIDE ASSY

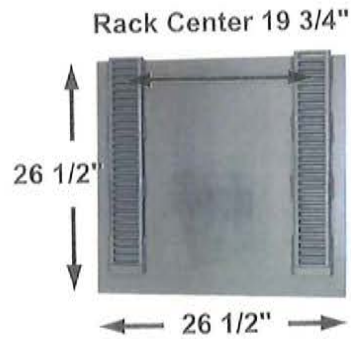

DA Part # : DA- 41254
 Ref # : 2CH-404
 Description: DOOR SLIDE ASSY

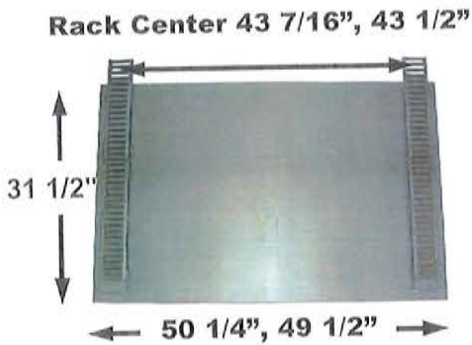

DA Part # : DA- 41329, DA-41328
 Ref # : 3CH-429, DA-41328
 Description: DOOR SLIDE ASSY

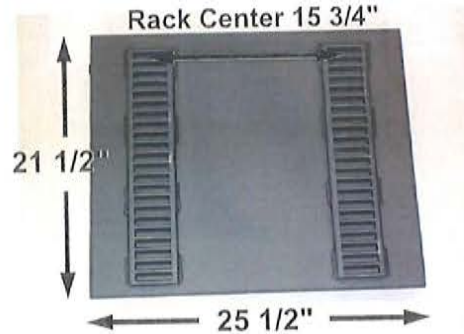

DA Part # : DA- 61294
 Ref # : 2CH-654-1
 Description: DOOR SLIDE ASSY



DA Part # : DA- 31808
 Ref # : PK-318-A
 Description: EXTENSION



DA Part # : DA- 31818
 Ref # : PK-318-B
 Description: EXTENSION



DA Part # : DA- 48908
Ref # : PK-489-A
Description: EXTENSION



DA Part # : DA- 48918
Ref # : PK-489-B
Description: EXTENSION



DA Part # : DA- 42498
Ref # : MC-498
Description: PIPE BRACKET



DA Part # : DA- 41517
Ref # : MC-477
Description: CORNER CAP



DA Part # : DA- 60606
Ref # : PK-6
Description: ECCENTRIC



DA Part # : DA- 31236
Ref # : PK-36
Description: ECCENTRIC



DA Part # : DA- 17025
Ref # : CL-25
Description: END CAP



DA Part # : DA- 32101
Ref # : PK-321-A
Description: EXTENSION



DA Part # : DA- 32102
Ref # : PK-321-B
Description: EXTENSION



DA Part # : DA- 40431
Ref # : PK-431-A
Description: EXTENSION



DA Part # : DA- 41431
Ref # : PK-431-B
Description: EXTENSION



DA Part # : DA- 41454
Ref # : PK-454-A
Description: EXTENSION



DA Part # : DA- 42454
Ref # : PK-454-B
Description: EXTENSION



DA Part # : DA- 42457
Ref # : PK-457-A
Description: EXTENSION



DA Part # : DA- 43457
Ref # : PK-457-B
Description: EXTENSION



DA Part # : DA- 44487
Ref # : PK-487-B
Description: EXTENSION



DA Part # : DA- 43487
Ref # : PK-487-A
Description: EXTENSION



DA Part # : DA- 47134
Ref # : PK-471-A-34
Description: EXTENSION



DA Part # : DA- 47234
Ref # : PK-471-B-34
Description: EXTENSION



DA Part # : DA- 47487
Ref # : PK-487-AX
Description: EXTENSION



DA Part # : DA- 48483
Ref # : PK-483-A
Description: EXTENSION



DA Part # : DA- 48493
Ref # : PK-483-B
Description: EXTENSION



DA Part # : DA- 48487
Ref # : PK-487-BX
Description: EXTENSION



DA Part # : DA- 42467
Ref # : MC-467
Description: EYEBOLT BRACKET



DA Part # : DA- 22611
Ref # : PK-261-B-1
Description: FILLER



DA Part # : DA- 12611
Ref # : PK-261-A-1
Description: FILLER



DA Part # : DA- 29261
Ref # : PK-261-B
Description: FILLER



DA Part # : DA- 28261
Ref # : PK-261-A
Description: FILLER



DA Part # : DA- 43511
Ref # : MC-511
Description: EYEBOLT BRACKET

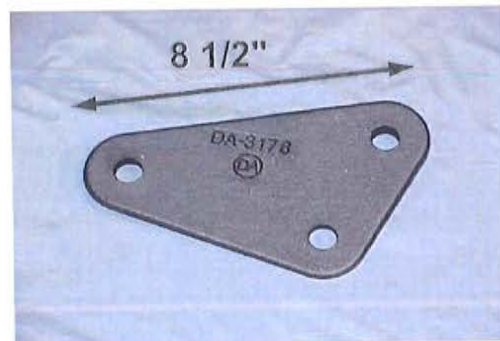

DA Part # : DA- 31780 w/ 13/16" holes
Ref # : DA-3178
Description: FILLER



DA Part # : DA- 48234
 Ref # : PK-482-A-34
 Description: BRACKET



DA Part # : DA- 48334
 Ref # : PK-482-B-34
 Description: BRACKET

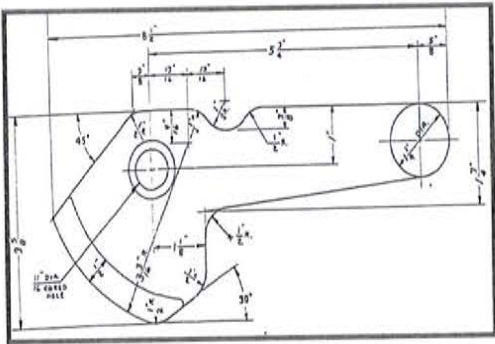

DA Part # : DA- 35323
 Ref # : MC-323
 Description: HATCH LOCK

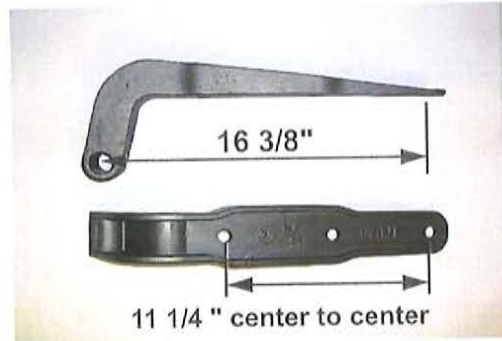

DA Part # : DA- 23261
 Ref # : HF-261
 Description: HINGE



DA Part # : DA- 25127
 Ref # : HF-127
 Description: HINGE



DA Part # : DA- 42499
 Ref # : MC-499
 Description: HINGE

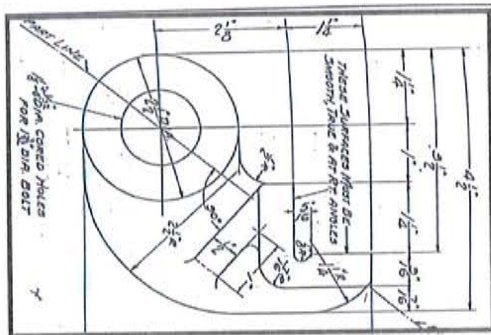

DA Part # : DA- 10139
 Ref # : 11139
 Description: HINGE BUTT



DA Part # : DA- 43512
 Ref # : MC-512
 Description: HINGE BUTT



DA Part # : DA- 68845
 Ref # : KIT
 Description: OUTLET GATE LOCK KIT

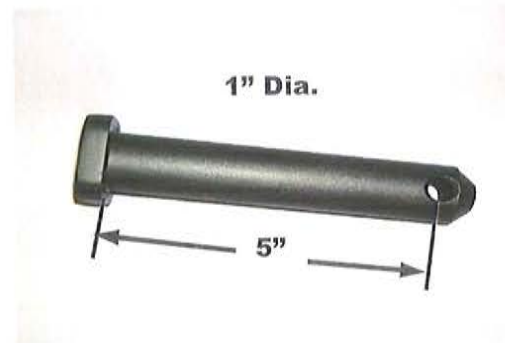

DA Part # : DA- 12545
 Ref # : DA-11512, DA-11746
 Description: HINGE PIN



DA Part # : DA- 17209
 Ref # : CL-19-A
 Description: HOOK (INSIDE)



DA Part # : DA- 17219
 Ref # : CL-19-B
 Description: HOOK (INSIDE)



DA Part # : DA- 22527
Ref # : PK-27-X
Description: HOOK



DA Part # : DA-25527
Ref # : PK-27
Description: HOOK

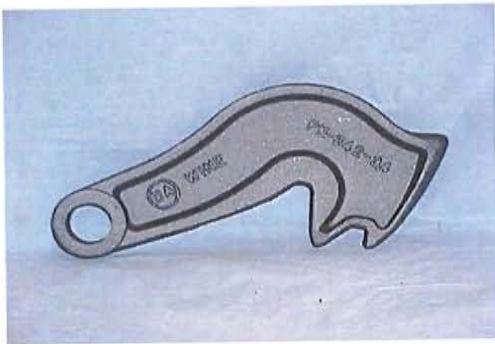

DA Part # : DA- 34234
Ref # : PK-342-34
Description: HOOK



DA Part # : DA- 43481
Ref # : PK-481
Description: HOOK



DA Part # : DA- 17028
Ref # : CL-28
Description: HOOK (INSIDE)



DA Part # : DA- 17160
Ref # : CL-60
Description: HOOK (INSIDE)



DA Part # : DA- 17156
Ref # : CL-66-A
Description: HOOK (OUTSIDE)



DA Part # : DA-17166
Ref # : CL-66-B
Description: HOOK (OUTSIDE)



DA Part # : DA- 17204
Ref # : CL-24-A
Description: HOOK (INSIDE)



DA Part # : DA- 17224
Ref # : CL-24-B
Description: HOOK (INSIDE)



DA Part # : DA- 17309
Ref # : CL-39-A
Description: HOOK (INSIDE)



DA Part # : DA- 17339
Ref # : CL-39-B
Description: HOOK (INSIDE)



DA Part # : DA- 17503
Ref # : CL-13-A
Description: HOOK (INSIDE)



DA Part # : DA-17513
Ref # : CL-13-B
Description: HOOK (INSIDE)



DA Part # : DA- 17349
Ref # : CL-59-A
Description: HOOK (OUTSIDE)



DA Part # : DA- 17359
Ref # : CL-59-B
Description: HOOK (OUTSIDE)



DA Part # : DA- 17605
Ref # : CL-65-A
Description: HOOK (OUTSIDE)



DA Part # : DA- 17665
Ref # : CL-65-B
Description: HOOK (OUTSIDE)



DA Part # : DA- 17512
Ref # : CL-12-A
Description: HOOK (OUTSIDE)



DA Part # : DA-17612
Ref # : CL-12-B
Description: HOOK (OUTSIDE)



DA Part # : DA- 23527
Ref # : CL-27-A
Description: HOOK (OUTSIDE)



DA Part # : DA- 23627
Ref # : CL-27-B
Description: HOOK (OUTSIDE)



DA Part # : DA- 28020
Ref # : CL-20-A
Description: HOOK (OUTSIDE)



DA Part # : DA- 28120
Ref # : CL-20-B
Description: HOOK (OUTSIDE)



DA Part # : DA- 17308
Ref # : CL-38-A
Description: HOOK (OUTSIDE)



DA Part # : DA-17338
Ref # : CL-38-B
Description: HOOK (OUTSIDE)

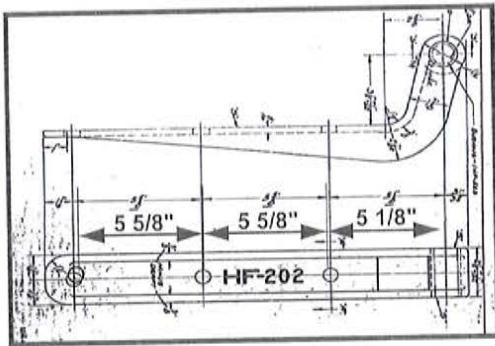

DA Part # : DA- 25202
Ref # : HF-202
Description: HINGE

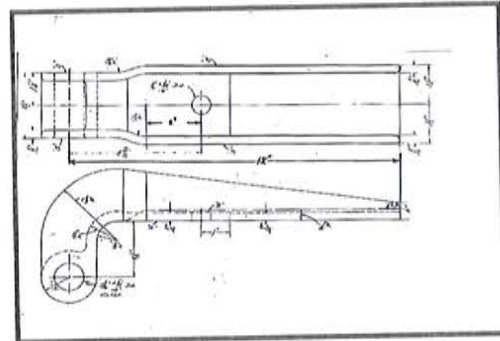

DA Part # : DA- 45496
Ref # : MC-496
Description: HINGE



DA Part # : DA- 48134
Ref # : PK-481-34
Description: HOOK

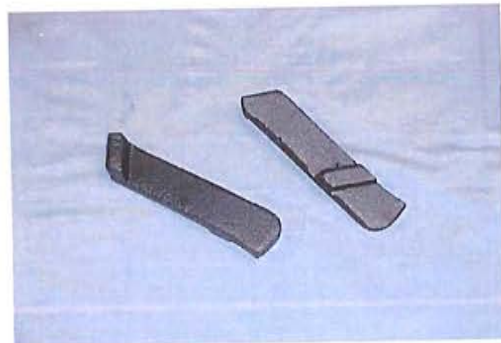

DA Part # : DA- 20209
Ref # : CH-209
Description: LATCH



DA Part # : DA- 20210
Ref # : 2CH-210
Description: LATCH RETAINER



DA Part # : DA-17417
Ref # : CL-7
Description: PAWL



DA Part # : DA- 28112
Ref # : PK-2-A
Description: PAWL



DA Part # : DA- 29112
Ref # : PK-2-B
Description: PAWL



DA Part # : DA- 32343
Ref # : PK-343-A
Description: PAWL



DA Part # : DA- 34343
Ref # : PK-343-B
Description: PAWL



DA Part # : DA- 43480
 Ref # :PK-480-A
 Description: PAWL



DA Part # : DA-44480
 Ref # : PK-480-B
 Description: PAWL



DA Part # : DA- 33178
 Ref # : 2CH-328
 Description: PINION GEAR

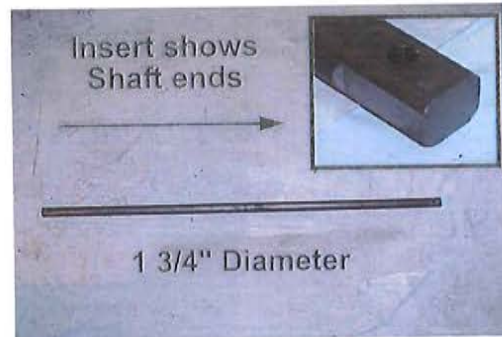

DA Part # : DA- 31033 = 61 inch
 DA Part # : DA- 33026 = 66 inch
CALL FOR ADDITIONAL LENGTHS
 Description: PINION SHAFTS



DA Part # : DA- 33179
 Ref # : 2CH-327
 Description: PINION GEAR (7")

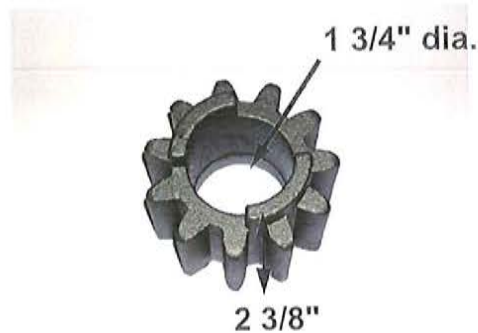

DA Part # : DA- 21129, DA- 21130
 Ref # : 2CH-29, DA-29-304-SS
 Description: PINION, CARBON, S.S.

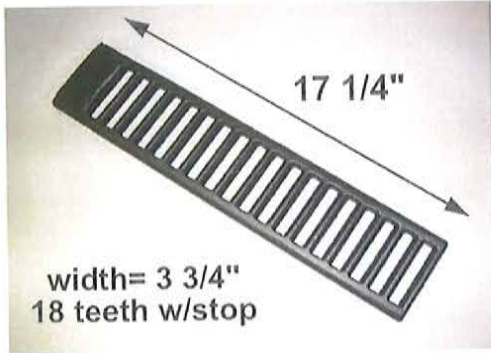

DA Part # : DA- 13096
 Ref # : 2CH-156
 Description: RACK

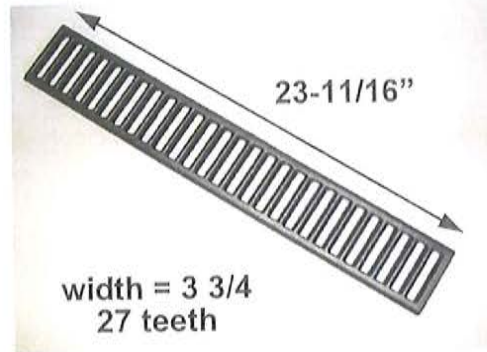

DA Part # : DA-33181
 Ref # : 2CH-331
 Description: RACK



DA Part # : DA- 45461
 Ref # : MC-461
 Description: FRONT DRAFT LUG

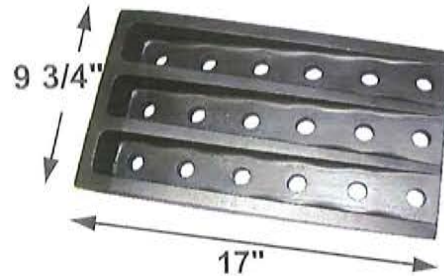

DA Part # : DA- 10028
 Ref # : CB-128
 Description: REAR DRAFT LUG

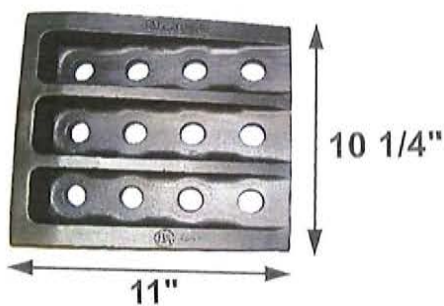

DA Part # : DA- 32220
 Ref # : CB-220
 Description: DRAFT LUG



DA Part # : DA- 33505
 Ref # : 3505-A
 Description: TRUCK DAMP



DA Part # : DA- 33605
 Ref # : PK-35
 Description: TRUNNION WASHER

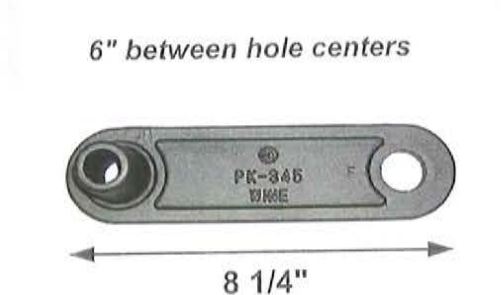

DA Part # : DA-37345
 Ref # : PK-345
 Description: TRUNNION WASHER



DA Part # : DA- 43455
 Ref # : PK-455
 Description: TRUNNION WASHER

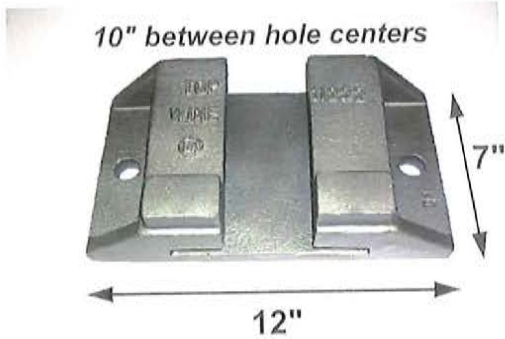

DA Part # : DA- 11222
 Ref # : 11222
 Description: VIBRATOR BRACKET

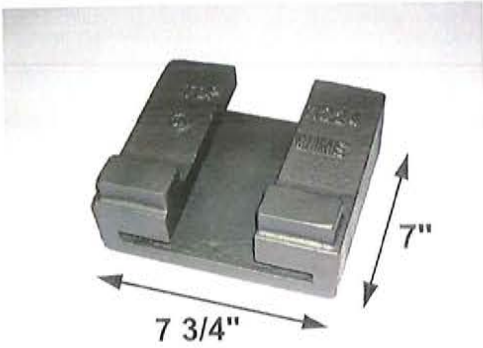

DA Part # : DA- 11224
 Ref # : 11224
 Description: VIBRATOR BRACKET

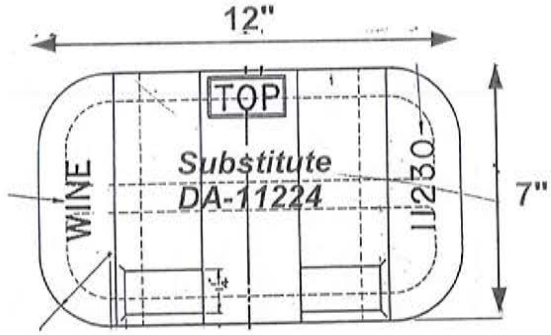

DA Part # : DA- 10230
 Ref # : 11230
 Description: VIBRATOR BRACKET

Rapid - Release™

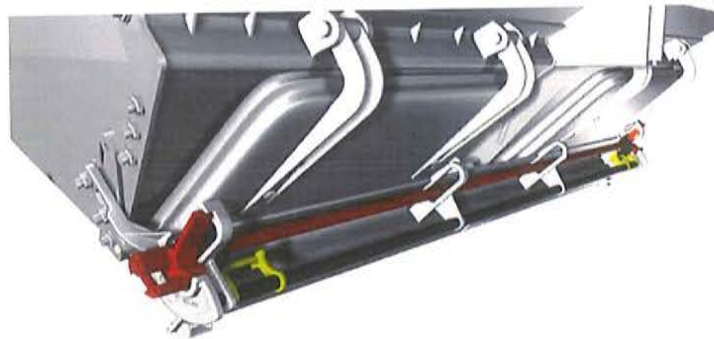

**DA Part # : DA-00640
Ref # : RR-640
Description: Rapid Release Cam Lock
Assembly For Narrow Door Application**



**DA Part # : DA-00640-1
Ref # : RR-640-1
Description: Rapid Release Cam Lock
Assembly For Narrow Door Application**

**DA Part # : DA-00642
Ref # : RR-642
Description: Rapid Release Cam Lock
Assembly For Wide Door Application**

**DA Part # : DA-00642-1
Ref # : RR-642-1
Description: Rapid Release Cam Lock
Assembly For Wide Door Application**



DA Part # : DA- 00611
Ref # : RR-611-L
Description: RAPID RELEASE HOOK (LH)



DA Part # : DA-00612
Ref # : RR-611-R
Description: RAPID RELEASE HOOK (RH)



DA Part # : DA- 00651
Ref # : RR-651-L
Description: RAPID RELEASE HOOK (LH)



DA Part # : DA- 00652
Ref # : RR-651-R
Description: RAPID RELEASE HOOK (RH)



DA Part # : DA- 00659
Ref # : RR-659-L
Description: RAPID RELEASE HOOK (LH)



DA Part # : DA- 00660
Ref # : RR-659-R
Description: RAPID RELEASE HOOK (RH)

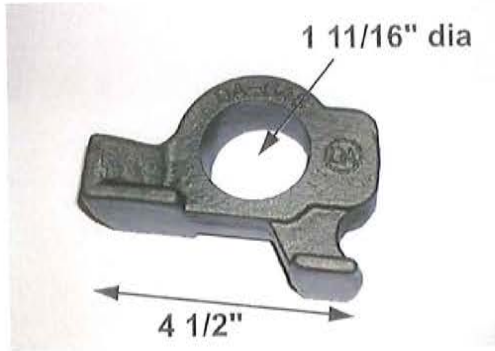

DA Part # : DA- 00648
 Ref # : DA-648
 Description: BEARING BLOCK
 Interchanges with Keystone

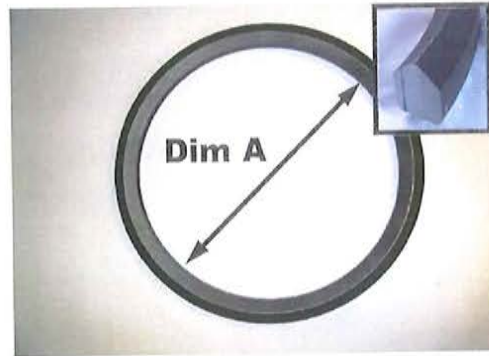

DA Part # : DA- 03654
 Ref # : DA-3654-140
 Description: BOLSTER RIM REPLACEMENT
 Dim A = 14"

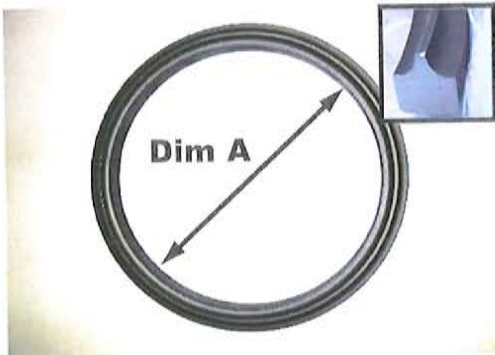

DA Part # : DA-03710, DA-03711
 Ref # : DA-3709-141, DA-3709-160
 Description: BOLSTER RIM REPLACEMENT
 Dim A = 14" 16"

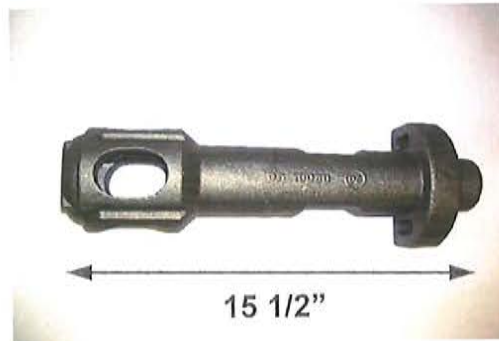

DA Part # : DA- 10080
 Ref # : E-10080
 Description: CAPSTAN
 Interchanges with Miner

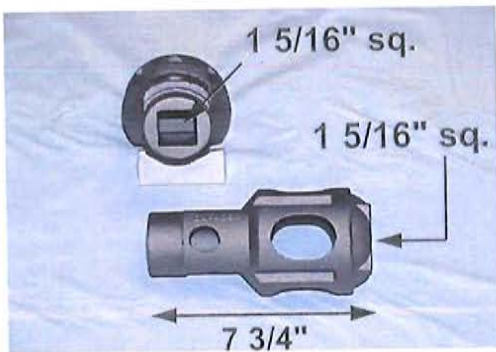

DA Part # : DA- 42391
 Ref # : DA-4081
 Description: CAPSTAN
 Interchanges with Miner



DA Part # : DA- 43413
 Ref # : DA-403
 Description: CAPSTAN
 Interchanges with Miner (E-5651)

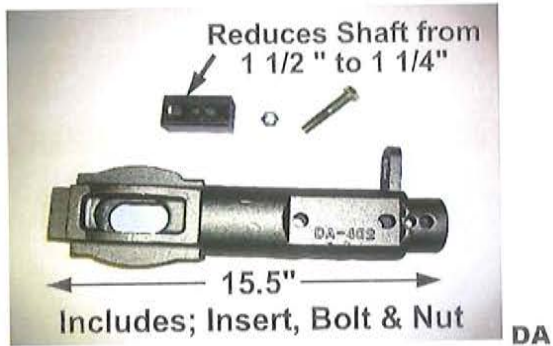

Part # : DA- 41902
 Ref # : DA-402
 Description: CAPSTAN (LONG UNIVERSAL)
 Interchange: Wine, Miner, Keystone, ACF

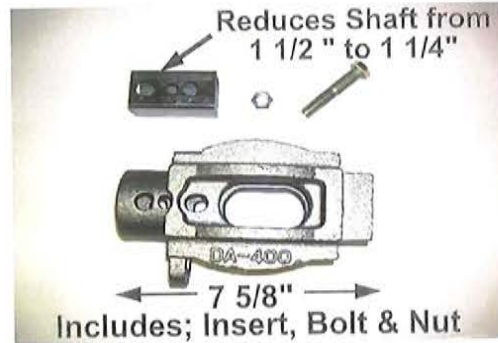

DA Part # : DA- 41890
 Ref # : DA-400
 Description: CAPSTAN (SHORT UNIVERSAL)
 Interchange: Wine, Miner, Keystone, ACF



DA Part # : DA- 43431, DA- 41424
 Ref # : 2CH-685, DA-404
 Description: Replacement for Power Unit
 Shaft Lengths: 61", 66"

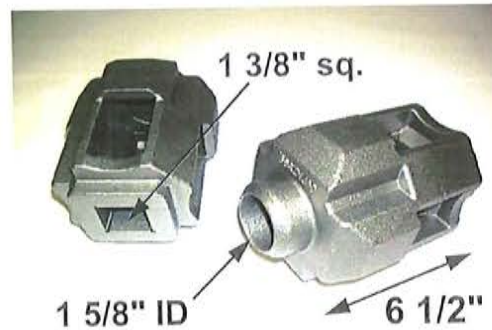

DA Part # : DA- 25690
 Ref # :
 Description: CAPSTAN
 Interchange with Keystone

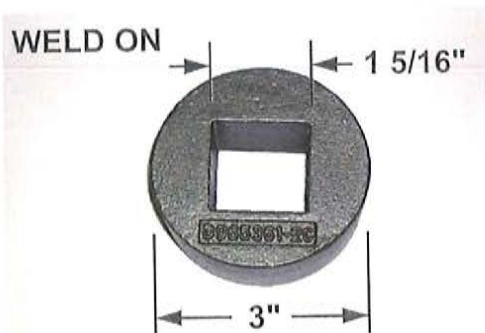

DA Part # : DA- 91701
 Ref # : D965361-2
 Description: CAPSTAN REINFORCEMENT



DA Part # : DA- 41932
 Ref # : DA-402-2
 Description: CAPSTAN, LONG HD



DA Part # : DA- 15154 , DA- 15155
Ref # : 50154-R , 50154-L
Description: REAR DRAFT LUG- R, L



DA Part # : DA- 14100
Ref # : D-10410-C
Description: STRIKER ASSEMBLY

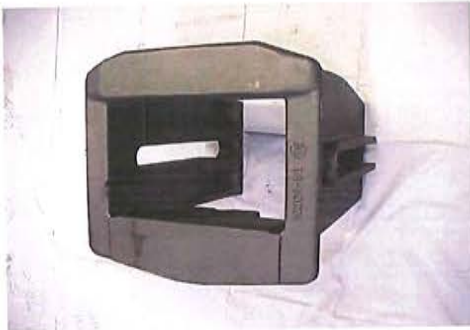

DA Part # : DA- 30001
Ref # : DA-30001
Description: STRIKER ASSEMBLY



DA Part # : DA- 32580, DA-32581
Ref # : 3799, 3258
Description: COUPLER CARRIER WEAR PLATE
Thickness: 9/32", 15/32"



DA Part # : DA- 44839
Ref # : 44839
Description: Friction Shoe



DA Part # : DA-53619, DA-53850
Ref # :
Description: Bell Crank, AAR 55, 66

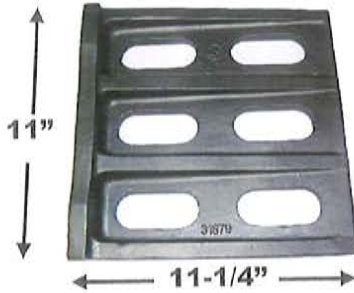

DA Part # : DA- 81777
 Ref # : 578106-0
 Description: DRAFT LUG, FRONT
 Interchange:



DA Part # : DA- 16298
 Ref # :
 Description: CAPSTAN
 Interchange:

*Future
 New Product*

DA Part #:
 Ref #:
 Description:



DA Part # : DA-08843
 Ref # : E-8843
 Description: CAPSTAN

*Future
 New Product*

DA Part # :
 Ref # :
 Description:

*Future
 New Product*

DA Part # :
 Ref # :
 Description:
 Interchange:

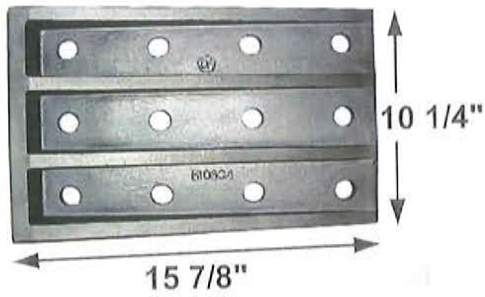

DA Part # : DA- 18004
 Ref # : B-10804
 Description: DRAFT LUG



DA Part # : DA- 16966
 Ref # : E-16096-B
 Description: STRIKER ASSEMBLY



DA Part # : DA- 50016
 Ref # : 093-40019
 Description: HINGE
 Interchange: Rapid Discharge Car

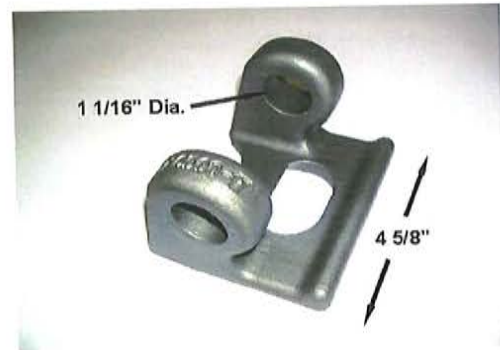

DA Part # : DA- 50017
 Ref # :
 Description: HINGE BUTT
 Interchange: Rapid Discharge Car

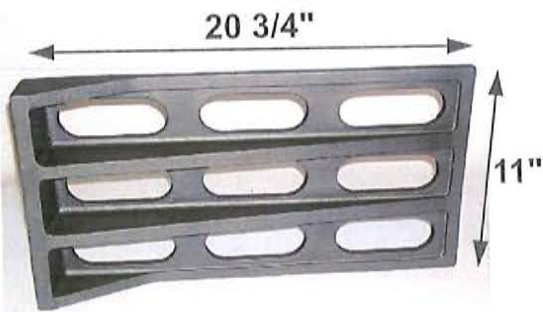

DA Part # : DA- 90346
 Ref # : B-9346
 Description: DRAFT LUG



DA Part # : DA- 12130
 Ref # : V-12130
 Description: HINGE



DA Part # : DA- 50300
 Ref # : DA-503
 Description: Stainless Steel Handle
 Interchange# :



DA Part # : DA- 17060
 Ref # : D1706039
 Description: Aluminum Hopper Door Pan
 For RD Car



DA Part # : DA- 92266
 Ref # : MB-999-5186
 Description: PLUNGER NOSE
 FOR FIFTH WHEEL



DA Part # : DA- 32272
 Ref # : M-336-5072
 Description: RELEASE HANDLE
 FOR FIFTH WHEEL



DA Part # : DA- 76035
 Ref # : AVAILABLE IN VARIOUS SIZES
 Description: HOPPER DOOR, TRAP. RH

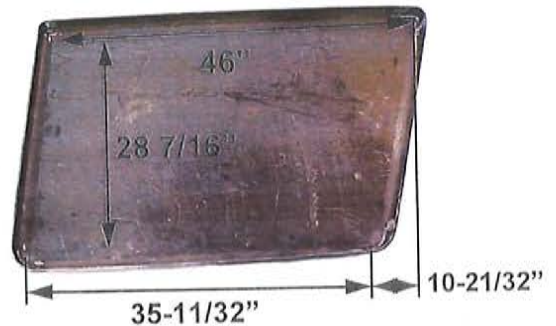

DA Part # : DA- 76031
 Ref # : AVAILABLE IN VARIOUS SIZES
 Description: HOPPER DOOR, TRAP. LH

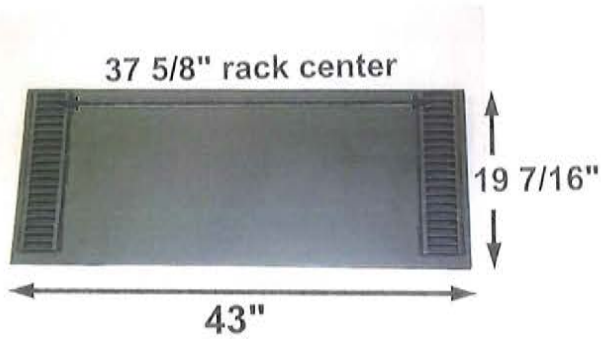

DA Part # : DA- 05374
Ref # : STYLE #6
Description: DOOR SLIDE ASSY
Interchange: Keystone

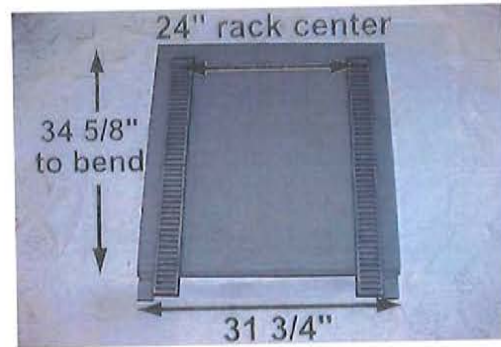

DA Part # : DA- 08410
Ref # : DA-08410
Description: DOOR SLIDE ASSY
Interchange: Keystone



DA Part # : DA- 176003
Ref # : SMALL
Description: HOPPER DOOR, SMALL
Available in SS or Carbon Steel



DA Part # : DA- 176004
Ref # : LARGE
Description: HOPPER DOOR, LARGE
Available in SS or Carbon Steel

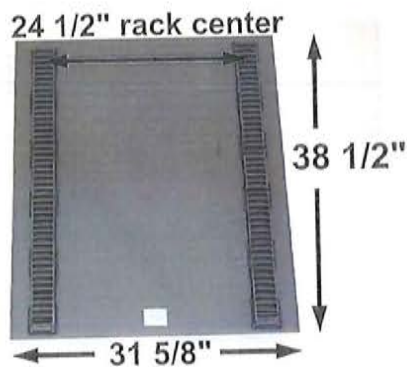

DA Part # : DA- 10062
Ref # : MKE-10062
Description: DOOR SLIDE ASSEMBLY
Interchange# : MINER

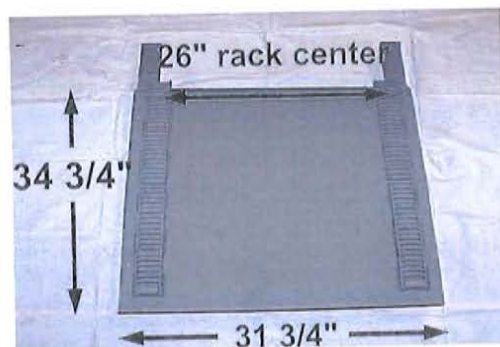

DA Part # : DA- 07987
Ref # : DA-7987
Description: DOOR SLIDE ASSEMBLY
Interchange#: MINER

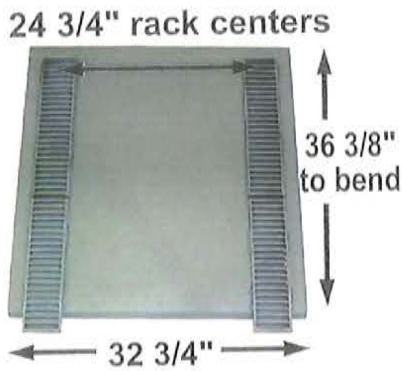

DA Part # : DA- 07118
 Ref # : DA-7118
 Description: DOOR SLIDE ASSEMBLY
 Interchange# : MINER

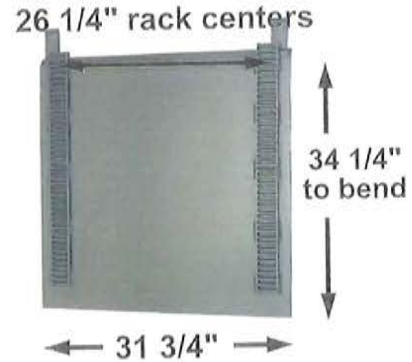

DA Part # : DA- 50287
 Ref # : STYLE #1
 Description: DOOR SLIDE ASSEMBLY
 Interchange# : MINER

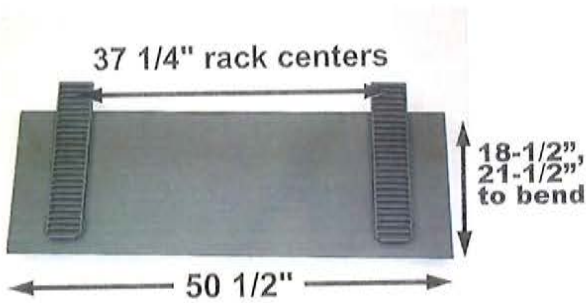

DA Part # : DA- 50202, DA-50204
 Ref # : STYLE #2, DA-50204
 Description: DOOR SLIDE ASSEMBLY
 Interchange# : MINER



DA Part # : DA- 50203
 Ref # : STYLE #3
 Description: DOOR SLIDE ASSEMBLY
 Interchange# : MINER

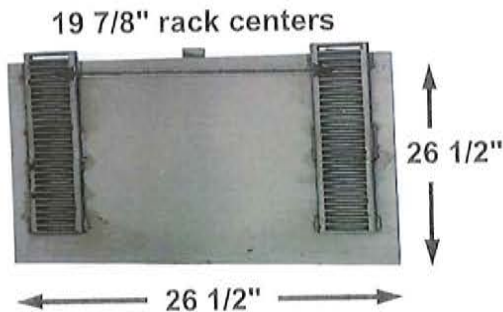

DA Part # : DA- 05804
 Ref # : STYLE #4
 Description: DOOR SLIDE ASSEMBLY
 Interchange# : ACF

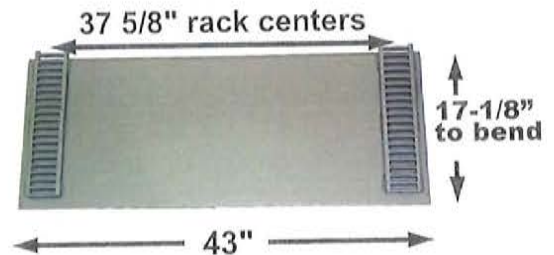

DA Part # : DA- 05765
 Ref # : STYLE #5
 Description: DOOR SLIDE ASSEMBLY
 Interchange# : ACF

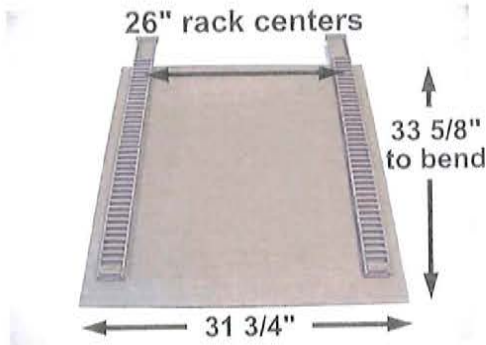

DA Part # : DA- 78134
Ref # : REPLACEMENT
Description: DOOR SLIDE ASS'Y
Interchange# : MINER

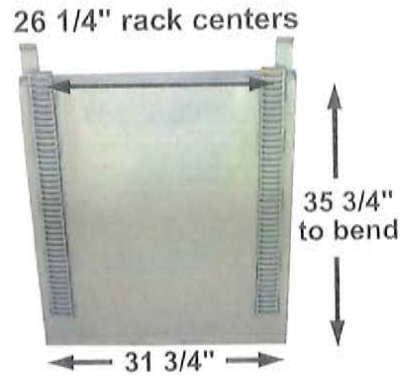

DA Part # : DA- 50289
Ref # : REPLACEMENT
Description: DOOR SLIDE ASS'Y
Interchange# : MINER

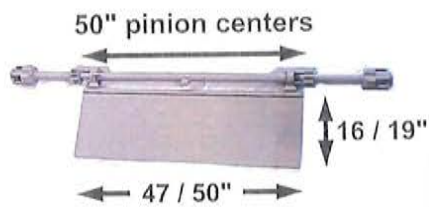

DA Part # : DA- 71106 / DA- 71150
Ref # : REPLACEMENT
Description: DOOR SLIDE ASS'Y
Interchange# : KEYSTONE

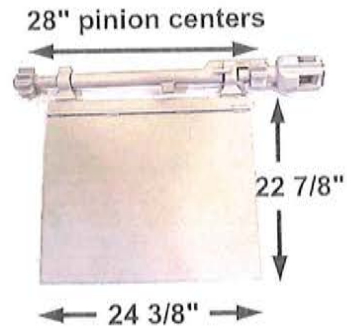

DA Part # : DA- 74510 / DA- 74520
Ref # : AS SHOWN / OPPOSITE
Description: DOOR SLIDE ASS'Y
Interchange # : KEYSTONE



DA Part # : DA- 71131
Ref # : REPLACEMENT
Description: DOOR SLIDE ASS'Y
Interchange# : KEYSTONE

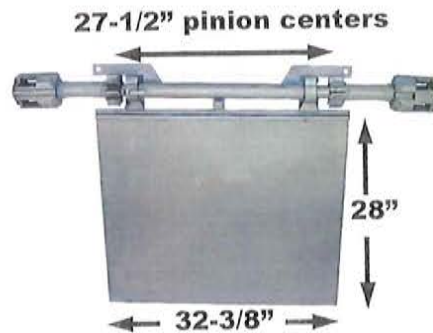

DA Part # : DA- 71140
Ref # : REPLACEMENT
Description: DOOR SLIDE ASS'Y
Interchange# : KEYSTONE

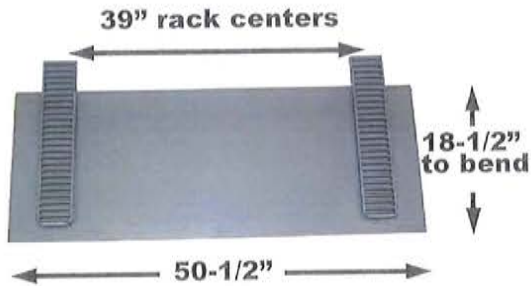

DA Part # : DA- 50209
 Ref # : REPLACEMENT
 Description: DOOR SLIDE ASS'Y
 Interchange# : MINER

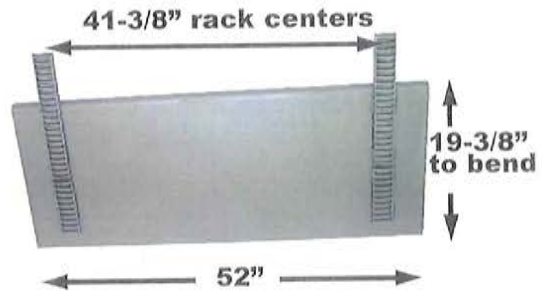

DA Part # : DA- 50210
 Ref # : REPLACEMENT
 Description: DOOR SLIDE ASS'Y
 Interchange# : MINER



DA Part # : DA- 71132, DA-71132-SP
 Ref # : REPLACEMENT
 Description: DOOR SLIDE ASS'Y
 Interchange# : KEYSTONE

*Future
New Product*

DA Part # : DA-
 Ref # :
 Description:
 Interchange # :

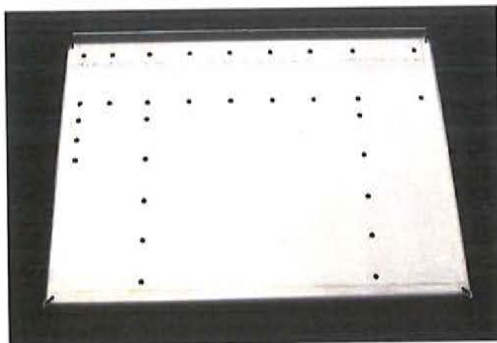

DA Part # : DA- 17002
 Ref # : D-170-7002
 Description: Aluminum Hopper Door
 Pan for RD Car, Left Hand

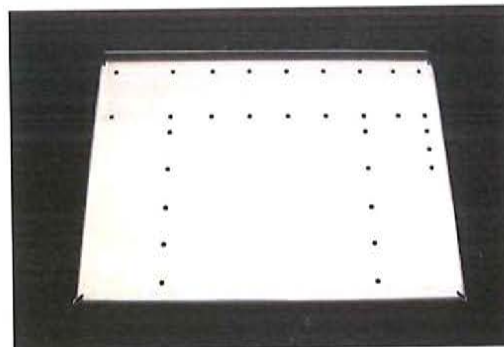

DA Part # : DA-17003
 Ref # : D-170-7003
 Description: Aluminum Hopper
 Door Pan for RD Car, Right Hand

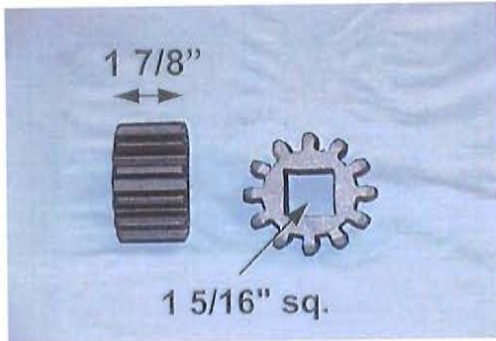

DA Part # : DA- 70209
 Ref # : DA-29
 Description: PINION GEAR
 Interchange: Miner

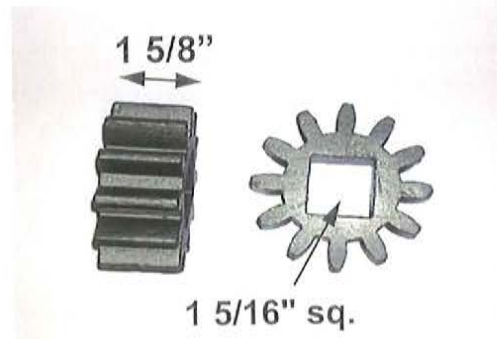

DA Part # : DA- 70210
 Ref # : DA-29-B
 Description: PINION GEAR

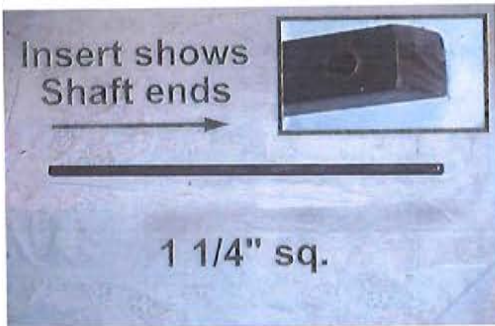

DA Part # : DA-01723 = 36 3/8 inch
 DA Part # : DA-01733 = 33 inch
 DA Part # : DA-07248 = 48 inch
 DA Part # : DA-07177 = 65 inch
 Description: PINION SHAFT

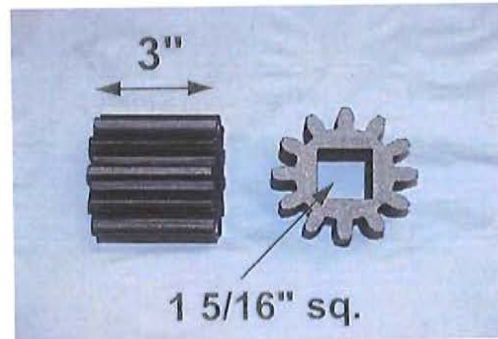

DA Part # : DA- 52082
 Ref # : DA-502
 Description: PINION GEAR
 Interchange: Miner

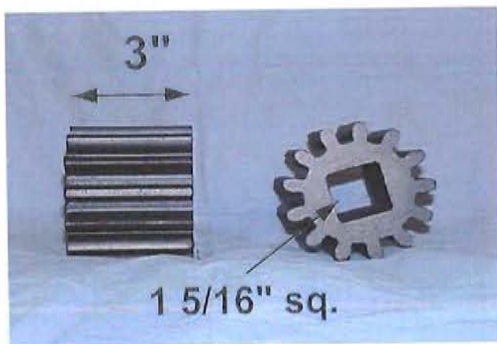

DA Part # : DA- 30304
 Ref # : DA-502-SS
 Description: PINION, STAINLESS STEEL

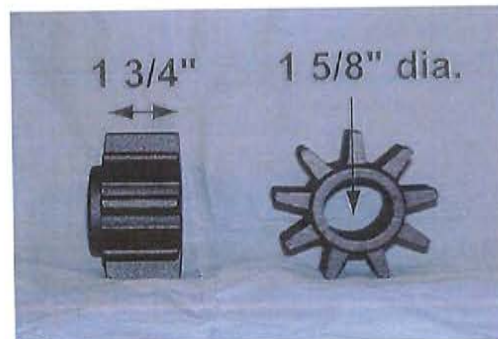

DA Part # : DA- 69400
 Ref # :
 Description: PINION GEAR
 Interchange: Keystone



DA Part # : DA- 70212
Ref # :
Description: PINION GEAR
Interchange:

*Future
New Product*

DA Part #:
Ref #:
Description:

*Future
New Product*

DA Part # :
Ref # :
Description:



DA Part # : DA- 10129
Ref # : E-10129
Description: PINION GEAR
Interchange: Miner

*Future
New Product*

DA Part # :
Ref # :
Description:

*Future
New Product*

DA Part # :
Ref # :
Description:
Interchange:



DA Part # : DA- 11007
Ref # : PC-117
Description: Latch Lug
Interchange: Keystone Mono Lock



DA Part # : DA- 11008
Ref # : PC-118
Description: Center Bearing
Interchange: Keystone Mono Lock



DA Part # : DA- 11900
Ref # : PC-119
Description: Eccentric
Interchange: Keystone Mono Lock



DA Part # : DA- 12000
Ref # : PC-120
Description: Outer Bearing
Interchange: Keystone Mono Lock



DA Part # : DA- 12100
Ref # : PC-121
Description: Latch
Interchange: Keystone Mono Lock



DA Part # : DA- 12200
Ref # : PC-122
Description: Bar Socket
Interchange: Keystone Mono Lock



DA Part # : DA- 12003
Ref # : PC-123
Description: LOCKING LEVER
Interchange: Keystone Mono Lock



DA Part # : DA- 81690
Ref # : DA-800040
Description: RAVE DOOR HANGER



DA Part # : DA- 30112
Ref # : 212-30112
Description: RAVE DOOR
TWO KNUCKLE HINGE LEAF

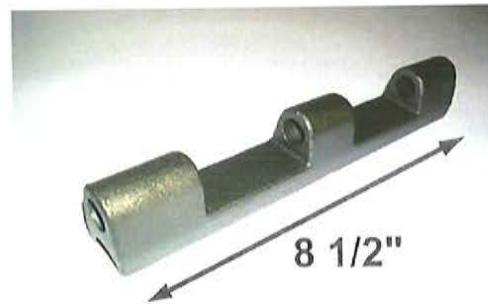

DA Part # : DA-30113
Ref # : 212-30113
Description: RAVE DOOR
THREE KNUCKLE HINGE LEAF



DA Part # : DA- 30119
Ref # : 212-30119-RH
Description: GUIDE FINGER FOR
RAVE DOOR



DA Part # : DA- 30115
Ref # : 212-30115-LH
Description: GUIDE FINGER FOR
RAVE DOOR



DA Part # : DA- 31780 w/ 13/16" holes
 Ref # : DA-3178
 Description: FILLER



DA Part # : DA- 04268
 Ref # : T-130
 Description: FULCRUM BRACKET



DA Part # : DA-50772, DA-50774, DA-52090
 Dimension "X" = 1-3/4", 2-1/16", 2-1/4"
 Description: LOCK WELD/SEAL PIN BRK'T
 ASS'Y, LEFT HAND

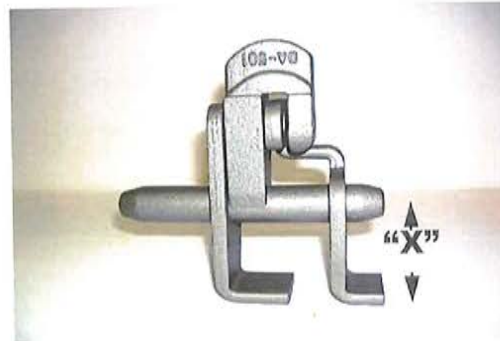

DA Part # : DA-50773, DA-50775, DA-52101
 Dimension "X" = 1-3/4", 2-1/16", 2-1/4"
 Description: LOCK WELD/SEAL PIN BRK'T
 ASS'Y, RIGHT HAND



DA Part # : DA- 43279
 Ref # : DA-043279
 Description: SEAL CAM ASSEMBLY

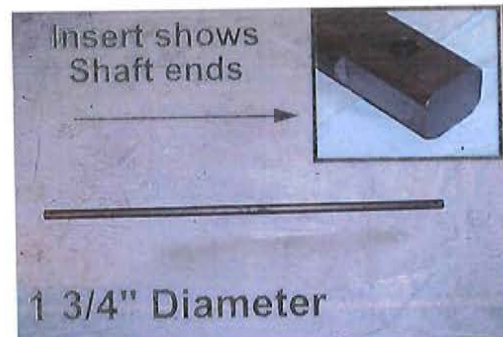

DA Part # : DA- 31033 = 61 inch
 DA Part # : DA- 33026 = 66 inch
CALL FOR ADDITIONAL LENGTHS
 Description: PINION SHAFTS

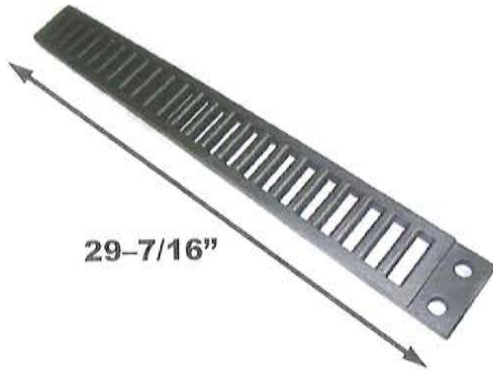

29-7/16"

DA Part # : DA- 00185
Ref # : 10085-2
Description: RACK

*Future
New Product*

DA Part # :
Ref # :
Description:



21-9/32"

DA Part # : DA-10111
Ref # :
Description: RACK
Interchange: Miner

*Future
New Product*

DA Part # :
Ref # :
Description:

*Future
New Product*

DA Part # :
Ref # :
Description:

*Future
New Product*

DA Part # :
Ref # :
Description:

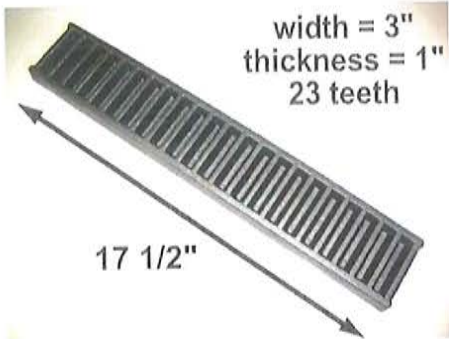

DA Part # : DA- 41423
Ref # : DA-423
Description: RACK
Interchange: Keystone

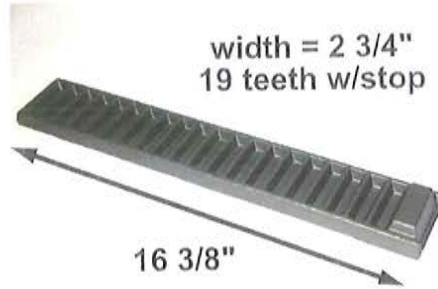

DA Part # : DA- 42339
Ref # : DA-4029
Description: RACK
Interchange: Miner

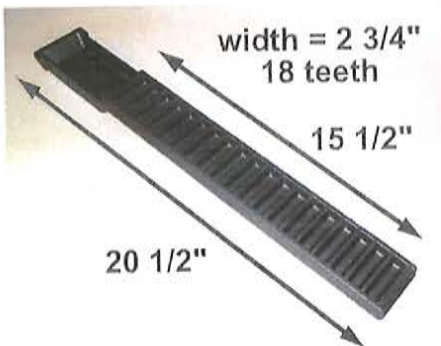

DA Part # : DA- 42340
Ref # : DA-4030
Description: RACK
Interchange: Miner

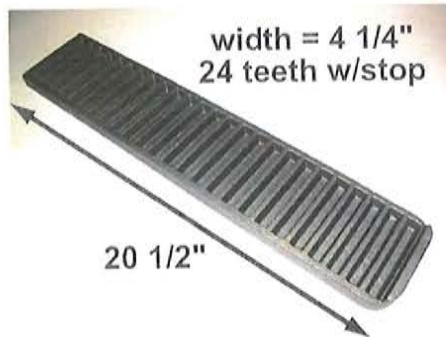

DA Part # : DA- 42372
Ref # : DA-422
Description: RACK
Interchange: Miner

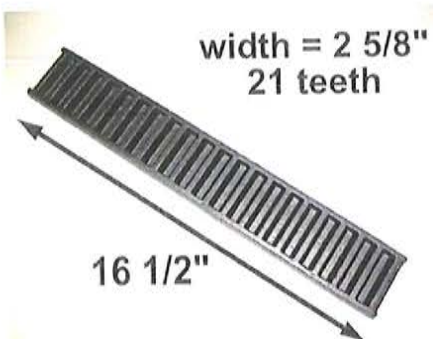

DA Part # : DA-42328
Ref # : DA-7028
Description: RACK
Interchange: Miner



DA Part # : DA- 42382
Ref # : VPA-6182
Description: RACK
Interchange: Keystone

width = 3"
17 teeth



DA Part # DA-42444
Ref # :
Description: RACK
Interchange: Keystone



DA Part # : DA-50094
Ref # :
Description: RACK



DA Part # : DA-28274
Ref # :
Description: GATE LOCK BAR ASS'Y



DA Part # : DA- 70213
Ref # :
Description: RACK

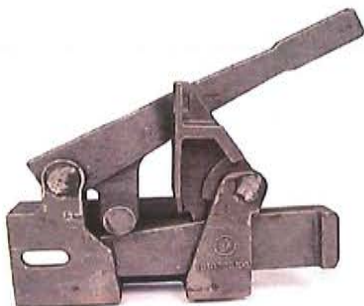

DA Part # : DA-23193
Ref # :
Description: WEDGE LOCK ASSEMBLY



DA Part # : DA-70100
Ref # : 3864
Description: Corner Cap



DA Part # : DA- 01710, DA- 01711
Ref # : 167-5000, 167-6000
Description: VIBRATOR BRACKET



DA Part # : DA- 52801
Ref # : E-51281
Description: ROPING CASTING



DA Part # : DA- 52802
Ref # : E-51282
Description: ROPING CASTING



DA Part # : DA-00850-1, DA-00850-2
Ref # : BENDABLE TAB
Description: KEEPER, DRAFT KEY RETAINER



DA Part # : DA- 50037
Ref # : 5050037
Description: DOOR STOP



DA Part # : DA- 41518
Ref # : DA-700
Description: CORNER CAP



DA Part # : DA- 09048
Ref # : 50067
Description: SPRING GUIDE AND STOP



DA Part # : DA- 50039
Ref # : 093-40028
Description: SPRING GUIDE



DA Part # : DA- 50040
Ref # : 093-40029
Description: SPRING GUIDE BRACKET



DA Part # : DA- 50066
Ref # : 093-40047
Description: SPRING GUIDE BRACKET CAP

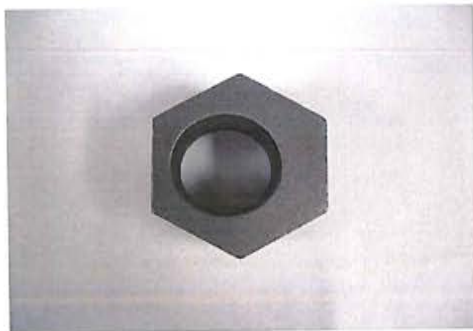

DA Part # : DA- 50068
Ref # : 093-40049
Description: ECCENTRIC NUT



DA Part # : DA- 50069
Ref # : 093-40050
Description: SPRING ASS'Y BRACKET



DA Part # : DA- 50090
Ref # :
Description: PIN FOR SPRING GUIDE



DA Part # : DA- 50034
Ref # : 50034
Description: SPRING GUIDE ADJMT. PLATE



DA Part # : DA- 50092
Ref # : 093-40389
Description: HINGE



DA Part # : DA- 40391
Ref # : 093-40391
Description: HINGE BUTT



DA Part # : DA-50070
Ref # : 093-40051
Description: LUG FOR SPRING ASSIST



DA Part # : DA-50030
Ref # : 093-40030, 500-41
Description: FULCRUM FOR SPRING ASSIST

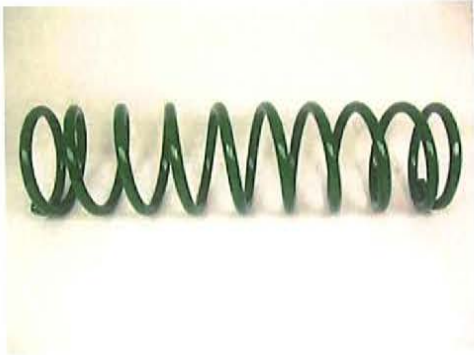

DA Part # : DA- 14123
Ref # : 131-40123
Description: SPRING FOR RD CAR



DA Part # : DA- 50038
Ref # : 131-40121
Description: SPRING FOR RD CAR



DA Part # : DA-50044
Ref # : 093-40035
Description: DOOR OPERATING LEVER

*Future
New Product*

DA Part # :
Ref # :
Description:



DA Part # : DA-47008
Ref # :
Description: RD HOPPER DOOR, INNER



DA Part # : DA-47009
Ref # :
Description: RD HOPPER DOOR,
OUTER



DA Part # : DA- 58330
Ref # : 38330
Description: Clevis Casting



DA Part # : DA- 57687
Ref # : 27687
Description: Lock Bolt Side



DA Part # : DA- 52340
Ref # : 2340
Description: Roller Assembly



DA Part # : DA- 53181
Ref # : 63181
Description: Connector Clevis



DA Part # : DA- 53229
Ref # : 53229
Description: Bracket, Lock Post



DA Part # : DA- 53548
Ref # : 10892
Description: Gear



DA Part # : DA-53555
Ref # : 53555
Description: Lever Adapter



DA Part # : DA-59411
Ref # : 29411
Description: Adjustable Crankshaft 304 SS

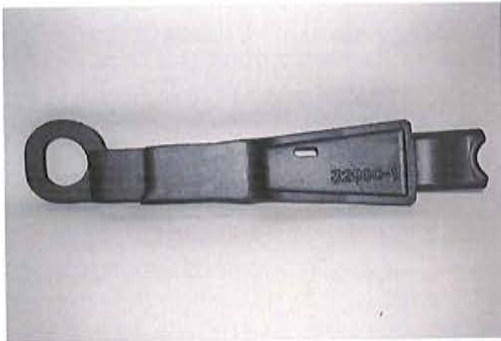

DA Part # : DA-53800
Ref # : 5155
Description: Hasp, Body Door



DA Part # : DA-53801
Ref # : 5157
Description: Hasp, Body End

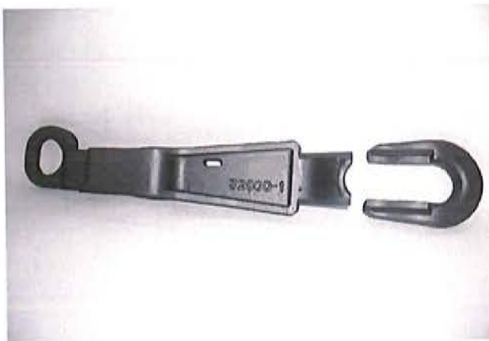

DA Part # : DA-53802
Ref # : 5156.0
Description: Hasp Body Door (2) two piece



DA Part # : DA-55159
Ref # : 5159
Description: Hasp lock



DA Part # : DA-56278
Ref # : 6278
Description: Adjustable Rod End



DA Part # : DA-56381
Ref # : 56381
Description: Bracket, Auxiliary Lock Sill



DA Part # : DA-57029
Ref # : 57029
Description: Handle Casting



DA Part # : DA-57382
Ref # : 27382
Description: Roller Stop Casting



DA Part # : DA-58030
Ref. # 58030
Description: Door Stop



DA Part # : DA-57400
Ref # : 27400
Description: Rod End Casting



DA Part # : DA-50498-1
Ref # : 50498
Description: Roller Housing w/o Hook



DA Part # : DA-57385-1
Ref # : 27349
Description: Roller Housing w/Hook



DA Part # : DA-57595
Ref # : 27595
Description: Anti Kick Back Pawl (Inner)



DA Part # : DA-57596
Ref # : 27596
Description: Anti Kick Back Pawl (Outer)



DA Part # : DA-34175
Ref # : 5463
Description: Ratchet Pawl



DA Part # : DA-57650
Ref # : 27650
Description: Ratchet Pawl



DA Part # : DA-57715
Ref # : 27715
Description: Pipe Bottom Extension



DA Part # : DA-58326
Ref # : 58326
Description: Bottom Crank & Extension Weldment



DA Part # : DA-60169
Ref # : 60169
Description: Bottom Crank & Extension Weldment



DA Part # : DA-58978
Ref # : 28978
Description: Lock Wedge Assembly



DA Part # : DA-58979
Ref # : 28979
Description: Lock Wedge Assembly



DA Part # : DA-58980
Ref # : 28980
Description: Lock Wedge Assembly



DA Part # : DA-50562
Ref # : 53562
Description: Cam, Lower Operating



DA Part # : DA-53559
Ref # : 53559
Description: Cam, Operating



DA Part # : DA-58992
Ref # : 28992
Description: Cam Casting, Seal



DA Part # : DA-59200
Ref # : 59200
Description: Cam, Upper Operating



DA Part # : DA-54494
Ref # : 41494
Description: Hole Open Arm



D. A. International Casting Co.

23 Industrial Parkway, Mansfield, OH 44903

Phone: 419-522-(CAST) 2278 • Fax: 419-524-1688

Website: www.dacasting.com